

mePed v2 Assembly Manual

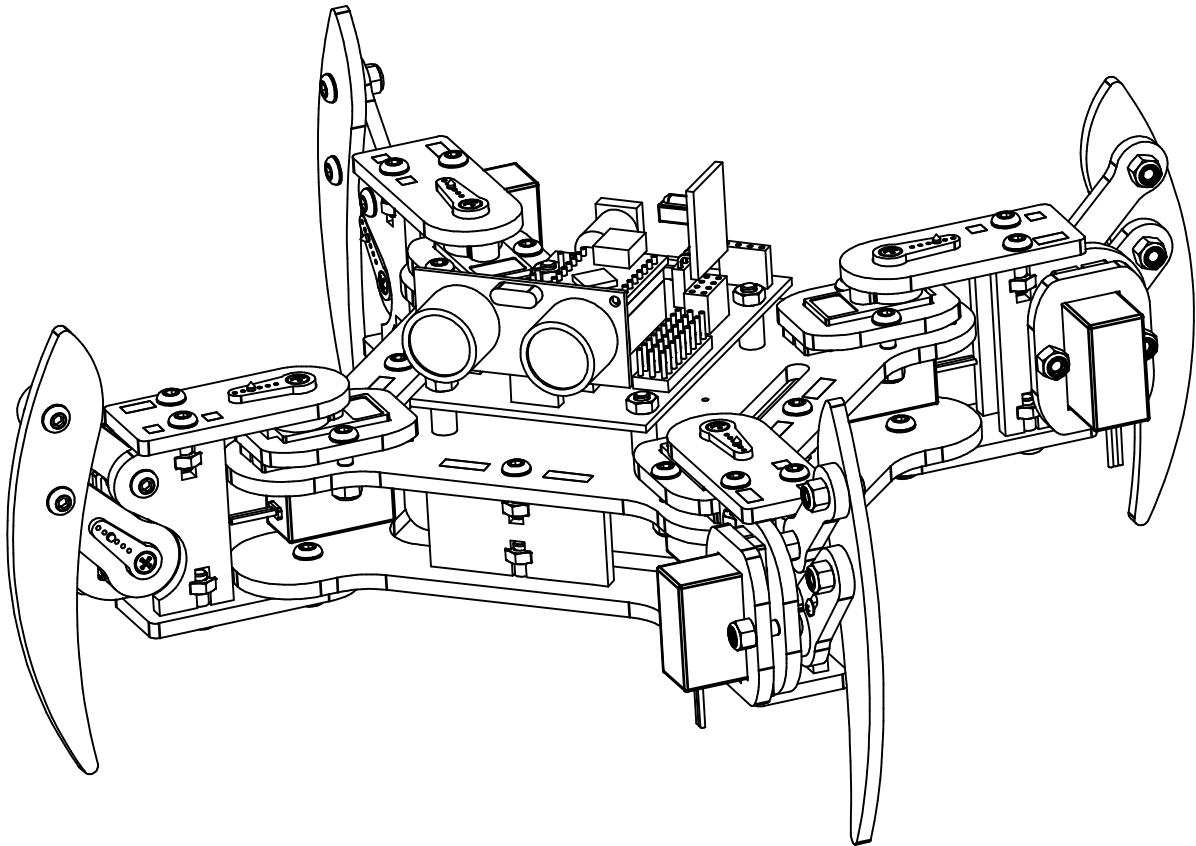

The mePed is an open source quadruped robot designed by Scott Pierce of Spierce Technologies, LLC. This design is released under the Creative Commons, By Attribution, Share Alike License. Please keep open source projects going for everyone! Hardware source files can be found at: www.meped.io

Additional information, wiring schematics, and sample programs can be found at the official website of the mePed: www.meped.io
Copyright © 2016 Spierce Technologies, LLC

Hardware:

Here is a list of fasteners and other hardware included with your new mePed. The Servo Screws and Servo Mount Screws referenced in this assembly manual are included with the servos and do not need to be purchased separately.

- 32ea - M3 Nyloc Nut
- 28ea - M3 Hex Nut
- 40ea - M3 x 10mm Screw
- 16ea - M3 x 12mm Screw
- 4ea - M3 x 16mm Screw
- 4ea - Nylon Spacer
- 1ea - Allen Wrench
- 1ea - End Wrench

WARNING:
CHOKING HAZARD - Small parts.
Not for children under 3 years.

Wood Parts:

Before laser cutting the mePed, the wood was covered with a protective masking tape to prevent the wood from becoming smoke damaged. You will need to peel the masking tape off each part before assembling the mePed. If there is a little bit of smoke damage anywhere on the wood after peeling off the masking tape, a light sanding will quickly remove it.

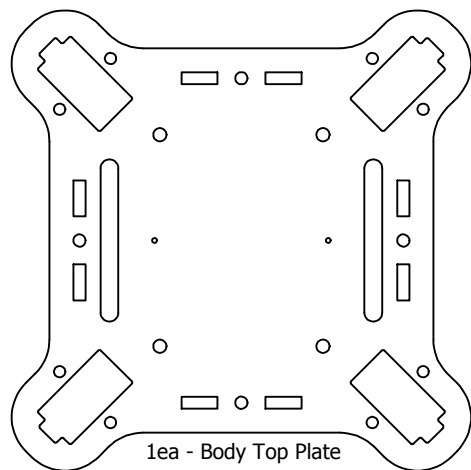

1ea - Body Top Plate

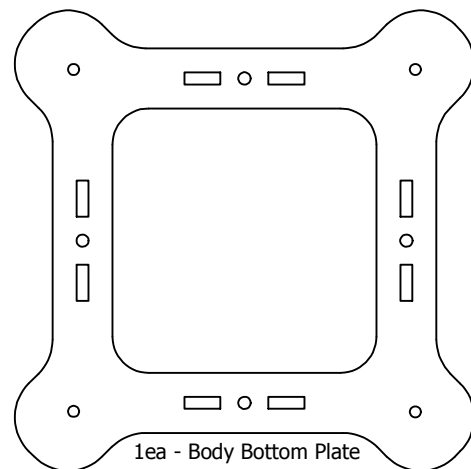

1ea - Body Bottom Plate

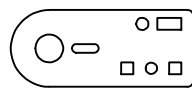

4ea - Leg Top Pivot Plate

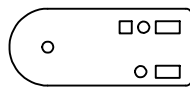

4ea - Leg Bottom Pivot Plate

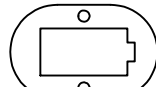

8ea - Servo Retainer

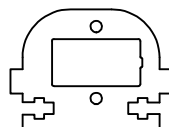

4ea - Leg Servo Mount

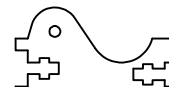

4ea - Leg Parallel Plate

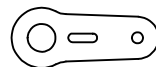

4ea - Leg Servo Arm

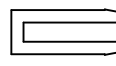

Mini mePed Retaining Clip

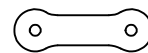

4ea - Leg Parallel Joint

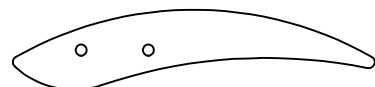

4ea - Leg



2ea - Battery Tray Spacer

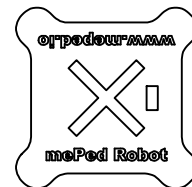

Mini mePed Body

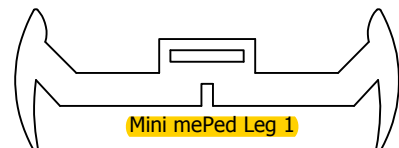

Mini mePed Leg 1

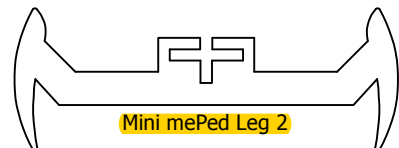

Mini mePed Leg 2



Mini mePed Head

**** NÃO ACOMPANHA O KIT**

Mini mePed

Along with the full size mePed kit, we have included a Mini mePed figurine to keep you company and help you build the full sized robot!

1. Insert Leg 1 into Body
2. Insert Leg 2 into Body
3. Insert Head into Body
4. Insert Retaining Clip through the notches in the Head

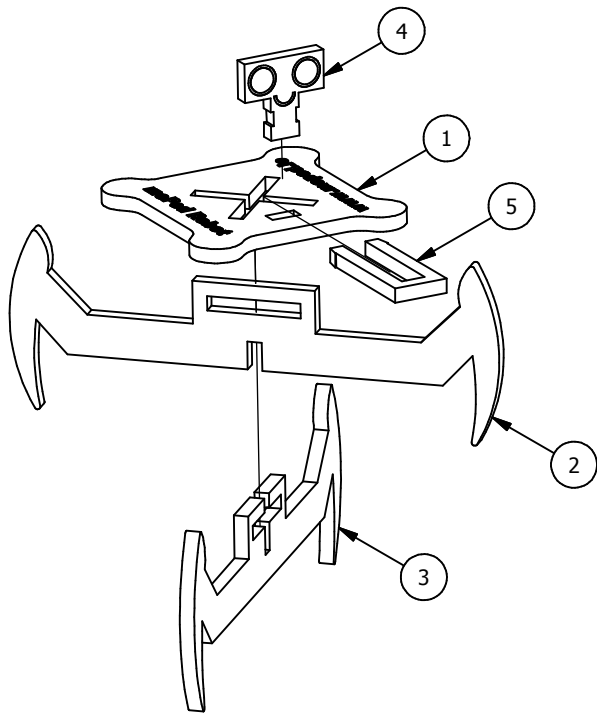

PARTS LIST	
ITEM	PART NUMBER
1	Body
2	Leg 1
3	Leg 2
4	Head
5	Retainer Clip

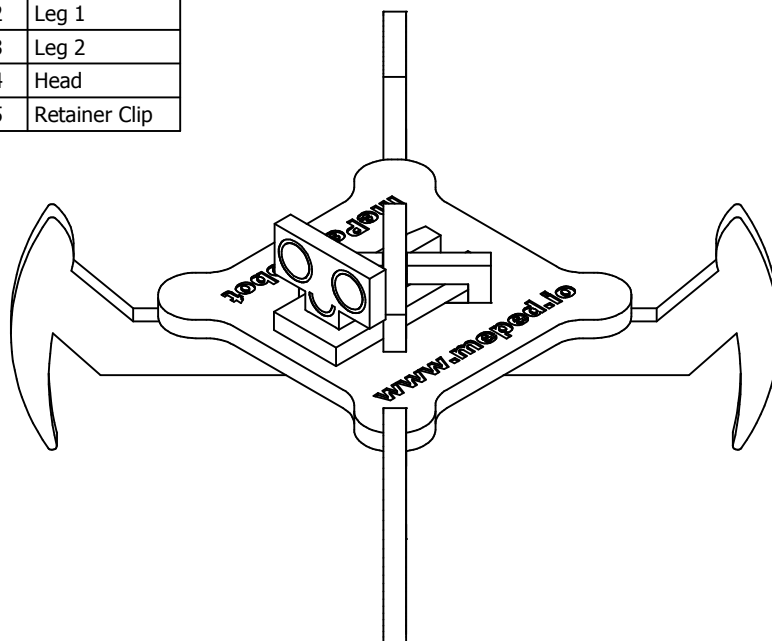

Setting Servo Center Position

Before starting to assemble your new mePed Walking Robot, it is important to center all 8 servos that came with the kit. The following steps will help ensure all of the servos are rotated to their center or 90° position.

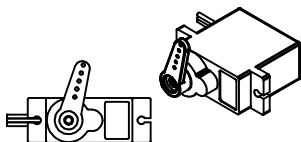

Attach a Servo Arm to the servo and then gently rotate the Servo Arm clockwise until the arm stops. It is okay if the Servo Arm does not stop at the same angle shown in the illustration above. What is important is that we find the end stop of the Servo.

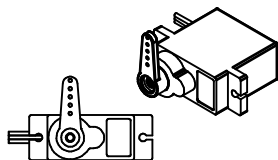

Remove the Servo Arm from the Servo and reposition it to be perpendicular to the Servo body as shown in this illustration.

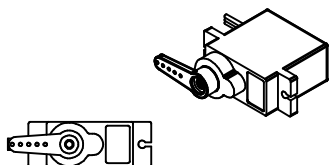

Gently rotate the Servo Arm counter-clockwise until the Servo Arm is parallel with the Servo body as shown. After the Servo Arm is parallel with the Servo Body, remove the Servo Arm and set it aside for later assembly. **This is the Servo's center position and it is important that all 8 Servos included in the kit are centered before starting the mePed assembly.**

Leg Assembly

Repeat Steps 1-9 four times.

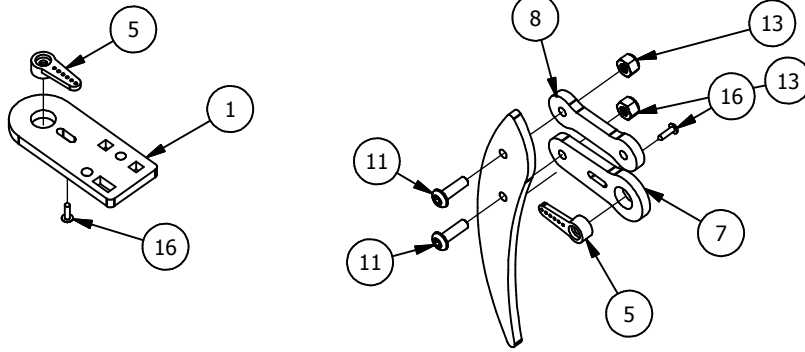

PARTS LIST	
ITEM	PART NUMBER
1	Leg Top Pivot Plate
2	Leg Bottom Pivot Plate
3	Leg Servo Mount
4	Servo Screw
5	Servo Single Arm
6	Servo
7	Leg Servo Arm
8	Leg Parallel Linkage
10	Leg Parallel Plate
11	M3 x 10mm Screw
12	M3 Plain Nut
13	M3 Nyloc Nut
14	M3 x 12mm Screw
15	Servo Retainer
16	Servo Mount Screw
17	Leg, Rev A

- Step 1: Insert a Servo Single Arm into a Leg Top Pivot Plate and thread a Servo Mount Screw into the Servo Single Arm from the back side of the Leg Top Pivot Plate.
- Step 2: Insert a Servo Single Arm into a Leg Servo Arm and thread a Servo Mount Screw into the Servo Single Arm from the back side of the Leg Servo Arm.
- Step 3: Attach one Leg Parallel Linkage to a Leg piece using an M3 x 10mm Screw and an M3 Nyloc Nut.
- Step 4: Attach the Leg piece to a Leg Servo Arm using an M3 x 10mm Screw and an M3 Nyloc Nut.
- IMPORTANT!** Do not over tighten the screws in Steps 2 and 3. The Leg joints should move freely to prevent excess friction which could cause the servos to fail.

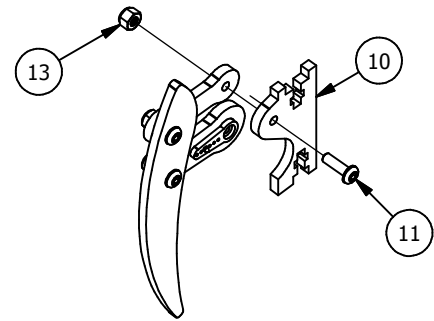
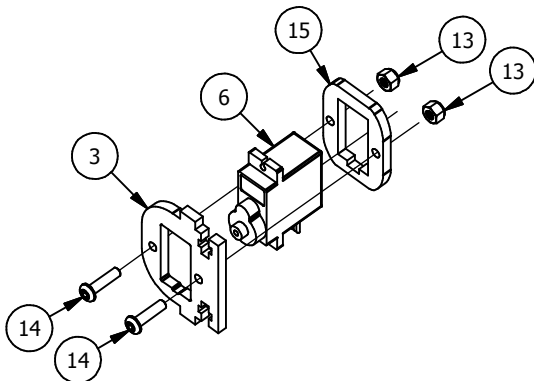

- Step 5: Insert a Servo into a Servo Retainer.
- Step 6: Insert the top end of the Servo into the Leg Servo Mount.
- Step 7: Attach the Servo Retainer to the Leg Servo Mount using two M3 x 12mm Screws and two M3 Nyloc Nuts.

- Step 8: Attach a Leg Parallel Plate to the other end of the Leg Parallel Linkage using an M3 x 10mm Screw and an M3 Nyloc Nut.
- IMPORTANT!** Do not over tighten this screw. The leg joints should move freely to prevent excess friction which could cause the servos to fail.

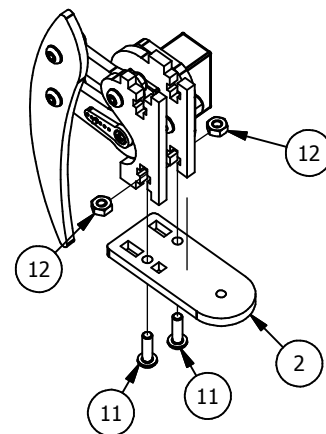
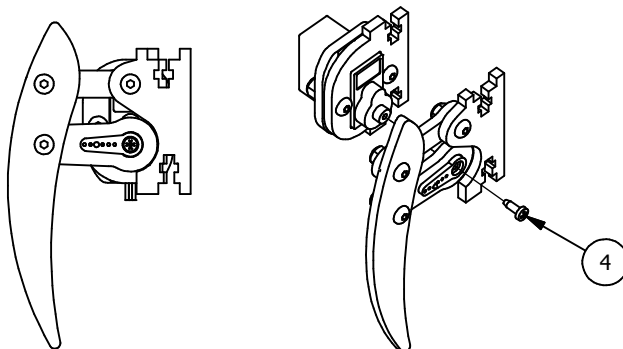

- Step 9: With the Servo rotated to center position and the leg positioned so the Parallel Linkage is horizontal, attach the Leg Servo Arm to the Servo using the Servo Arm Screw supplied with the Servo.

- Step 10: Attach the Leg Assembly from the previous steps to a Leg Bottom Pivot Plate using two M3 x 10mm Screws and two M3 Plain Nuts.

Body Assembly

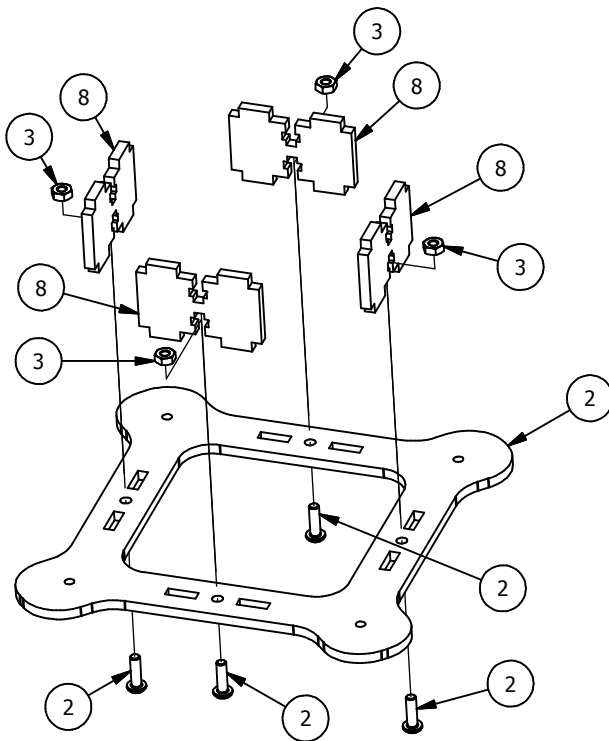

PARTS LIST	
ITEM	PART NUMBER
1	Body Top Plate
1	Servo Screw
3	9 Gram Servo
2	M3 x 10mm Screw
3	M3 Plain Nut
4	M3 Nyloc Nut
7	M3 x 12mm Screw
8	Body Spacer
9	Leg Servo Mount
10	Servo Retainer
20	Leg, Rev A

Step 11: Attach four Body Spacers to the Body Bottom Plate using four M3 x 10mm Screws and four M3 Plain Nuts.

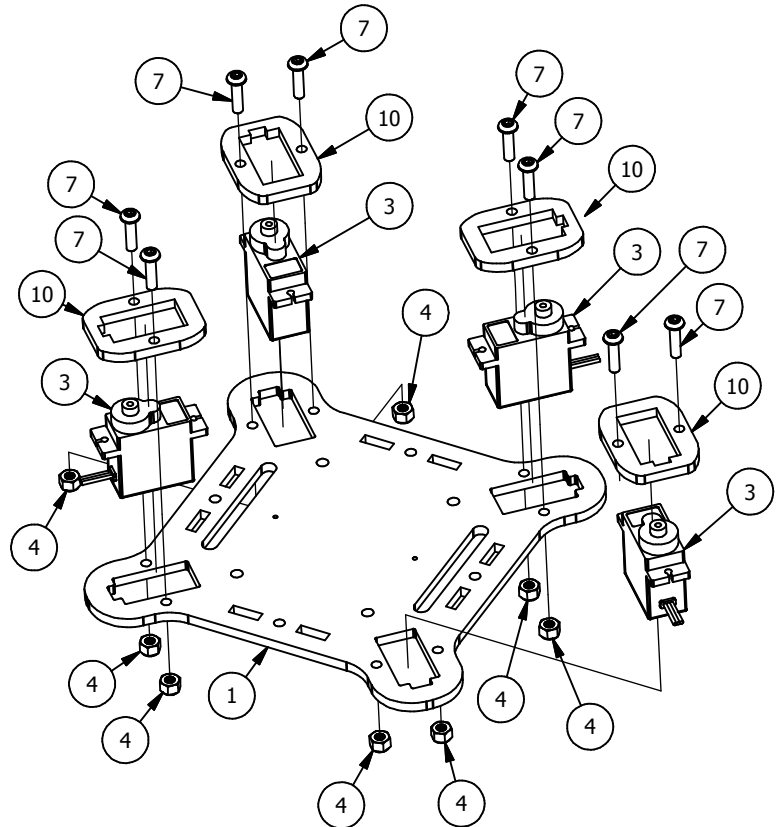

Step 12: Insert four Servos into the top side of the Body Top Plate.
 Step 13: Slide a Servo Retainer onto the top of each Servo.
 Step 14: Attach each Servo Retainer to the Body Top Plate using M3 x 12mm Screws and M3 Nyloc Nuts.

Final Assembly

PARTS LIST	
ITEM	PART NUMBER
1	Servo Screw
2	M3 x 10mm Screw
3	M3 Plain Nut
4	M3 Nyloc Nut
20	Leg, Rev A

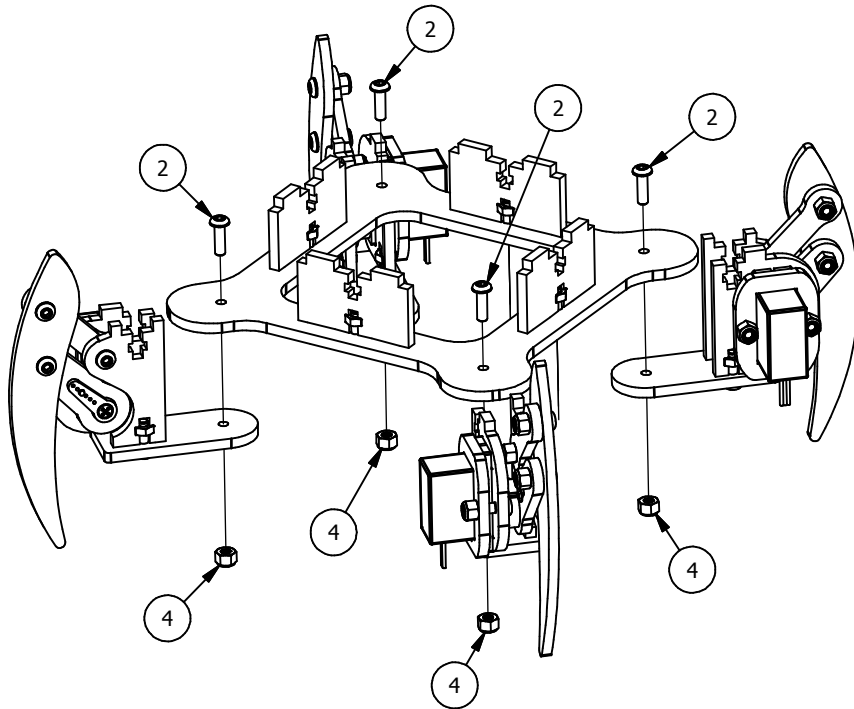

Step 15: Attach each Leg Assembly to the Body Bottom Plate Assembly using an M3 x 10mm Screw and an M3 Nyloc Nut. Do not over tighten these screws. The leg joints should move freely to prevent excess friction which could cause the servos to fail.

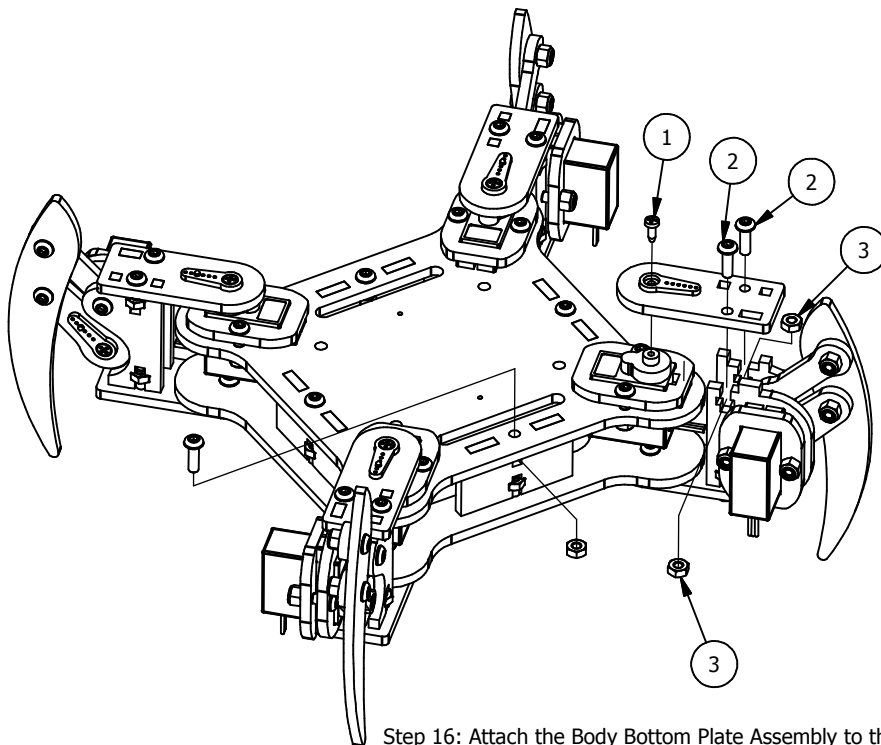

Step 16: Attach the Body Bottom Plate Assembly to the Body Top Plate Assembly using four M3 x 10mm Screws and four M3 Plain Nuts.

Step 17: Rotate each Leg so they are oriented at a 45° angle as shown. Attach a Leg Top Pivot Plate Assembly to each Pivot Servo and Leg Assembly using two M3 x 10mm Screws and two M3 Plain Nuts.

Step 18: Secure the Servo Single Arm to the Servo using a Servo Screw.

PARTS LIST	
ITEM	PART NUMBER
3	M3 Plain Nut
19	Servo Mount Screw
21	Battery Holder
22	mePed Circuit Board
24	Spacer, M3 x 8mm
25	M3 x 16mm Screw
26	Battery Tray Spacer

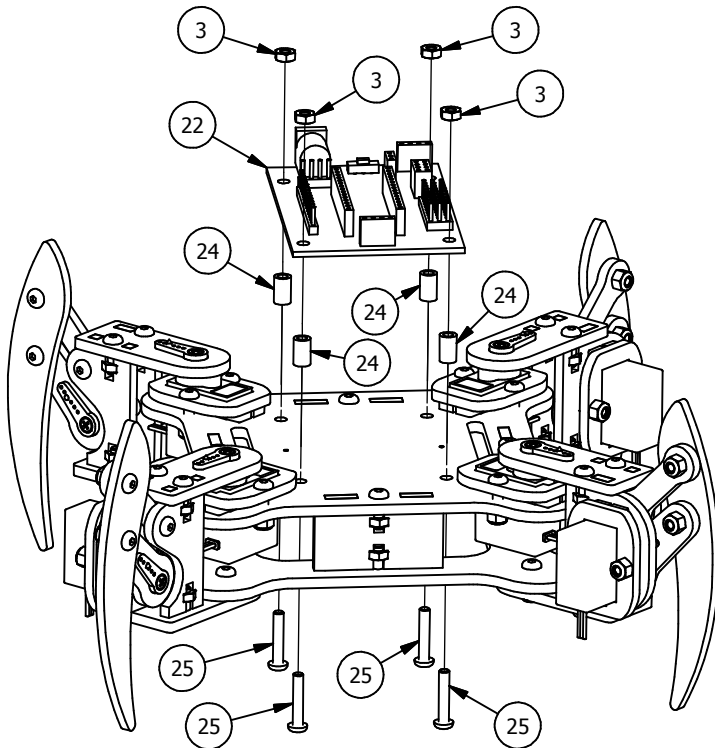

Step 19: Attach the mePed Circuit Board to the Body Top Plate using four M3 x 16mm Screws, four M3 x 8mm Spacers, and four M3 Plain Nuts.

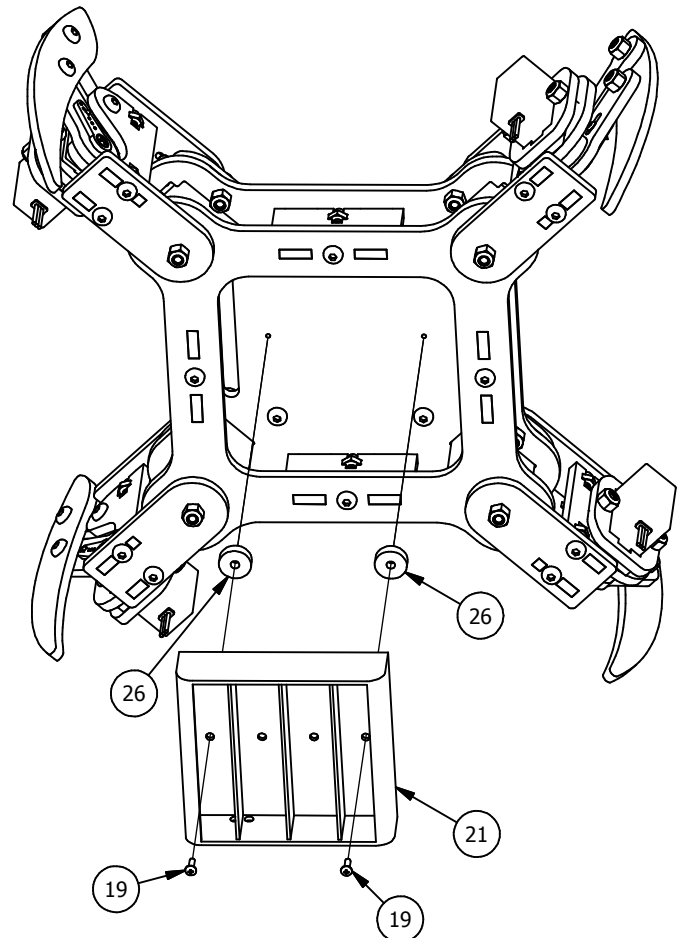

Step 20: Attach the Battery Holder to the bottom of the Body Top Plate using two Servo Screws and two Battery Holder Spacers. Feed the battery cable through the back of the mePed body and plug it into the match power socket on the mePed circuit board.

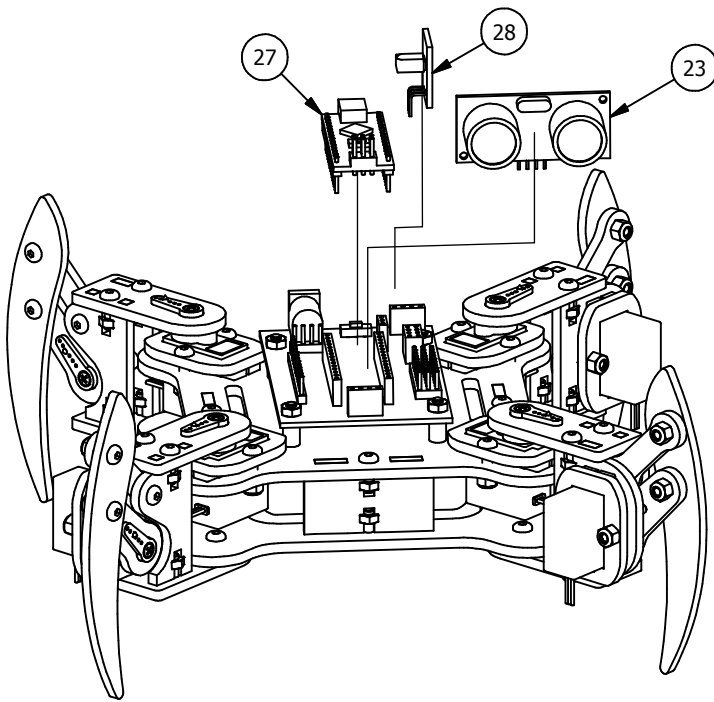

PARTS LIST	
ITEM	PART NUMBER
23	HC-SR04 Ultrasonic Range Finder
27	Arduino Nano
28	IR Sensor

- Step 21: Plug the HC-SR04 Ultrasonic Range Finder into the port labeled ULTRASONIC RF of the mePed Circuit Board.
- Step 22: Plug the Arduino Nano micro controller into the port labeled Nano on the mePed Circuit Board. Be sure the USB port on the Arduino Nano is facing away from the Ultrasonic Range Finder as shown in the illustration. Failure to orient the Arduino Nano correctly can permanently damage it.
- Step 23: Insert the IR Sensor into the port labeled IR on the mePed Circuit Board. Be sure to orient the IR Sensor as shown. The pin labeled "S" on the IR Sensor should plug into the socket labeled SIG on the mePed Circuit Board.

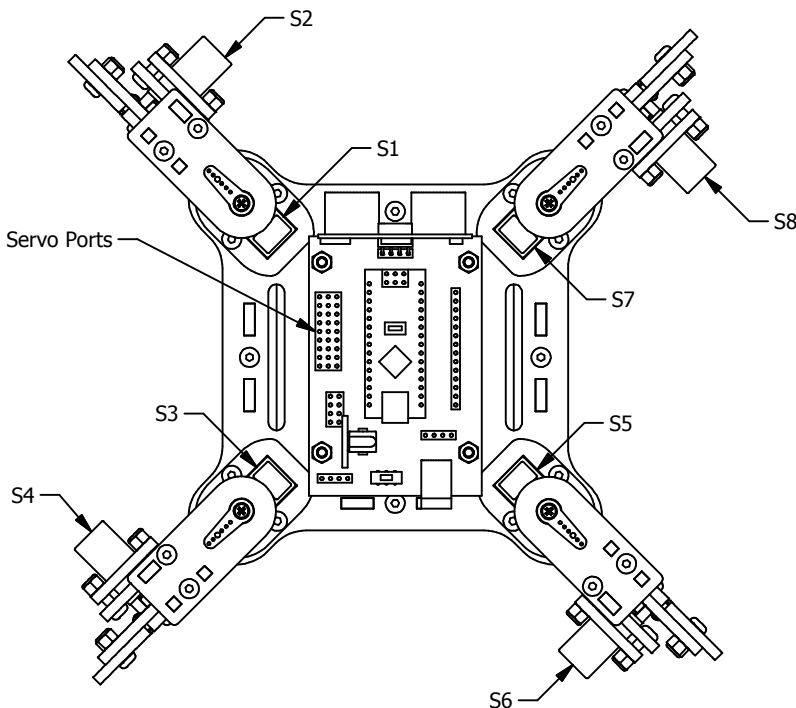

- Step 24: Plug the servos into the Servo Ports as follows:
 NOTE: The Orange wire of the servo goes to the S terminal and the Brown wire goes to "-" terminal on the mePed Circuit Board.

- Front Left Pivot Servo into S1
- Front Left Lift Servo into S2
- Back Left Pivot Servo into S3
- Back Left Lift Servo into S4
- Back Right Pivot Servo into S5
- Back Right Lift Servo into S6
- Front Right Pivot Servo into S7
- Front Right Lift Servo into S8

S9 is intentionally left empty but can accommodate an extra servo for added customization.

After your mePed robot is fully assembled and all the servo motor wires are plugged into their corresponding pins, insert four AA batteries into the battery holder on the bottom side of the robot and use the power switch to turn the robot on.

Here is a list of the pre-programmed remote control functions that are already on your mePed robot.

IR Remote

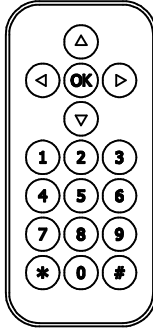

Up - Walk Forward
Down - Walk Backwards
Left - Turn Left
Right - Turn Right
OK -
1 - Walk Turn Walk
2 - Wave
3 - Increase Walking Speed
4 -
5 -
6 - Decrease Walking Speed
7 -
8 - Dance
9 -
0 - Move all servos to center position
* - Trim Left
- Trim Right

Buttons that do not have a movement associated with them are intentionally left un-programmed so you can program your own custom functions.

You can download the starter program already loaded onto your mePed as well as find other resources for your new robot at www.meped.io/mepedv2.