



MANUAL DE INSTRUÇÕES

RÁPIDO E PRÁTICO

PEÇAS			
(01)  Encosto	(02)  Assento	(03)  Braços	(04)  Mecanismo
(05)  Base Giratória	(06)  Telescópio	(07)  Pistão	(08)  Suporte de Encosto
(a)  Parafuso			

Passo 01

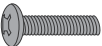
Fixar os braços (03) na parte inferior do assento (02). Utilizar 2 parafusos (a) para cada braço.

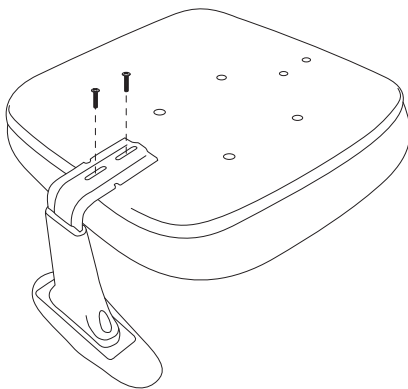

Passo 02

Fixar o mecanismo (04). Utilizar 4 parafusos (a).

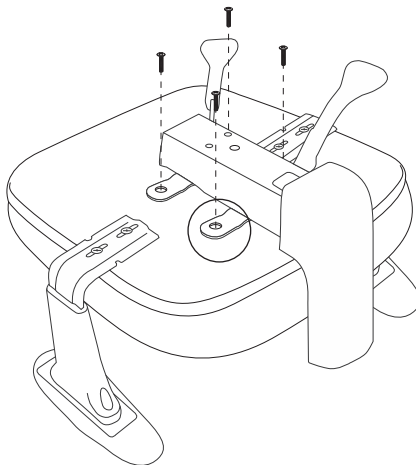

Passo 03

Verificar se o pino do suporte de encosto (08) está em seu devido lugar. Esse pino irá garantir que o conjunto do encosto não saia facilmente do conjunto do assento após serem encaixados um no outro.

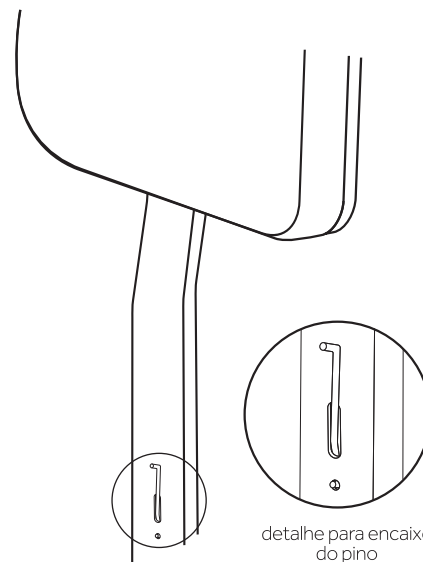

Passo 04

Fixar o suporte de encosto (08) no encosto (01). Utilizar 2 parafusos (a).

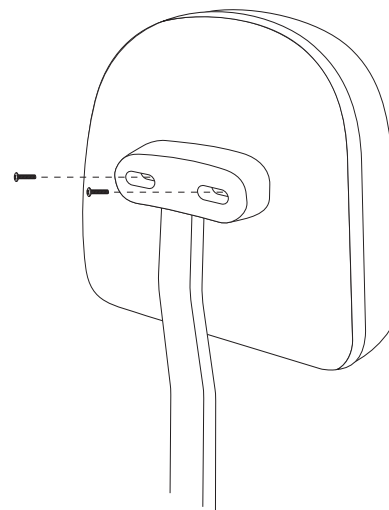

Passo 05

Encaixar todos os conjuntos montados nos passos anteriores e o telescópio (06) com o pistão (07) na base giratória (05), para enfim concluir a montagem da cadeira.

