

LED Stage Lighting Operating Manual



PRO 800 IP BSW



Please read manual carefully before use.

CONTENTS

Chapter 1 Installation and attention	1
Maintenance	1
Statement	1
Safety Precaution	1
Product Instruction	1
Cable connection (DMX)	2
Rigging (Optional)	2
RDM Note	3
Chapter 2 Panel operation	5
1. Brief	5
Operation	5
Operate fixture with touch button	5
Parameter value setting	5
Boolean parameter setting	6
Sub Menu (Parameter)	6
Anti-false touch operation of key	7
Operation and parameter instruction	7
1. DMX Address setting	8
Fixture operating mode setting	8
Set display	9
Scene	10
Set light run parameter	11
Status and information	12
Chapter 3 Channel description	15
1. Channel table	15

Chapter 1 Installation and attention

Maintenance

- To reduce the risk of electrical shock or fire, do not expose this unit to rain or moisture.
- Intermittently using will extend this item's service life.
- Please clear the fan, fan net, and optical lens in order to keep good work state.
- Do not use the alcohol or any other organic solvent to wipe the shell.

Statement

The product has perfect performance and integrity packing. All users should be strictly complying with the warning and operating instructions as stated. Or we aren't in charge of any result by misusing. Any damage resulting by misuse is not within the Company's warranty. Any fault or problem caused by neglecting the manual is also not in the charge of dealers.

Note: All information is subject to change without prior notice.

Safety Precaution

- In order to guarantee the product's life, please don't put it in the damp places or even the environment over 60degrees.
- Always mount this unit in safe and stable matter.
- Install or dismantle should operate by professional engineer.
- Using lamp, the change rate of power voltage should be within $\pm 10\%$. If the voltage is too high, it will shorten the light's life; If it's not enough, will influence the effect.
- Please restart it 20 minutes later after turning off light, until full-cooling. Frequent switching will reduce the life span of lamps and bulbs; intermittent using will improve the life of bulbs and lamps.
- In order to make sure the product is used well, please read the Manual carefully.

Product Instruction

- Lamp: LED 800W
- Powersupply:800W
- Channel mode:24CH DMX512 Channel
- Pan scan: 540°(16bit) Electric correction
- Tilt scan: 270° (16bit) Electric correction
- Spot zoom angle:4-35degrees
- Wash angle:10-0 35degrees

- Color wheel: 6 colors + white, half-color function, linear CMY+CTO color mixing
- Gobo: 6 static gobos, 7 glass gobos.
- Prism: 6-facet prism and 8-facet prism.
- Over heat protection
- IP: IP66
- Power Input: 100-240V, 50/60Hz
- Weight: 22.5kg
- Product size: 36*27*68cm (L*W*H)

Cable connection (DMX)

Use a cable conforming to specifications EIA RS-485: 2-pole twisted, shielded, 120Ohm characteristic impedance, 22-24 AWG, low capacity. Do not use microphone cable or other cable with characteristics differing from those specified. The end connections must be made using XLR type 3 or 5-pin male/female connectors. A terminating plug must be inserted into the last projector with a resistance of 120Ohm (minimum 1/4 W) between terminals 2 and 3.

IMPORTANT: The wires must not make contact with each other or with the metal casing of the connectors. The casing itself must be connected to the shield braid and to pin 1 of the

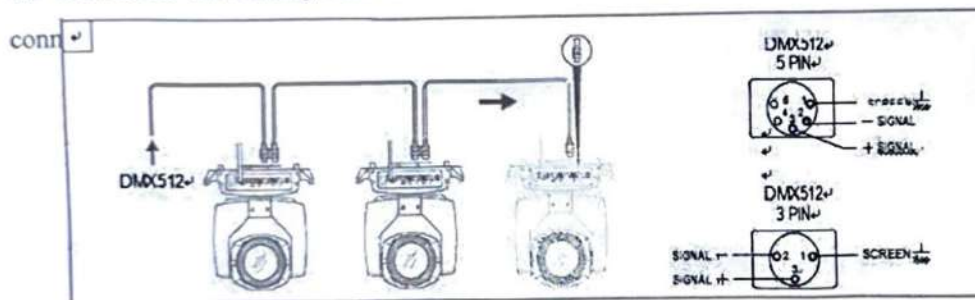

Figure 1 DMX Cable connection

Rigging (Optional)

This equipment can be positioned and fixed by clamp in every direction of the stage. Locking system makes it easy to fasten to the bracket.

Attention! Two clamps is needed to fix the equipment. Every clamp is locked by fastener of 1/4 kind. Fastener can only be locked clockwise.

Attention! Fasten a safety string to the additional hole of side aluminum piece. The secondary

accessory can not hang on the delivery handle. Nip the equipment on bracket.

- Check if rigging clamp (not including the one inside) damaged or not? If stand ten times weight as the equipment. Make sure the architecture can stand ten times weight as all the equipment, clamps, wirings and other additional fixtures.
- Screws for clamping must be fixed firmly. Take one M12 screw (Grade 8.8 or higher) to clamp bracket, and then screw the nuts. equipment
- Level the two hanging points at the bottom of clamp. Insert fastener to the bottom, lock the two levers by 1/4 rotating clockwise; then install another clamp.
- Install on safety string which stands at least ten times weight as equipment. Terminal of the accessory is designed for clamps.
- Make sure pan/tilt lock unlocked or not. Keep the distance more than 1M from equipment to flammable material or lighting source.

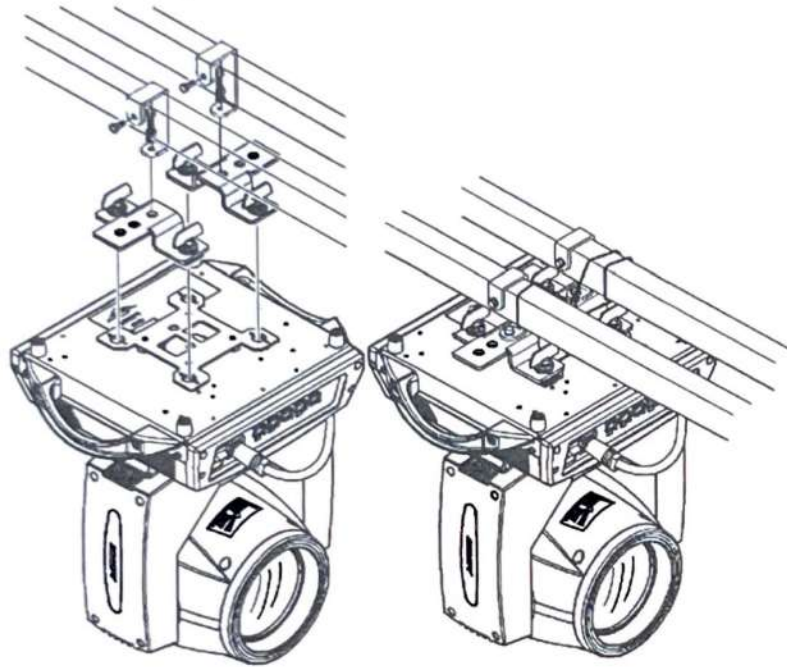

Figure 2 Installation

RDM Note

RDM is an extended version of DMX512-A protocol. It is a remote device management protocol. Traditional DMX512 protocol communication is one-way communication. The protocol is based on RS-485 bus. RS-485 is a time-sharing multi-point, half-duplex protocol. Only one port is allowed to output at the same time. So, when using RDM, we should pay attention to it. The following points:

- To use console or host device that supports RDM host protocol.

- Use bidirectional signal amplifier, traditional one-way signal amplifier is not suitable for RDM protocol, because the RMD protocol needs feedback data, the use of one-way amplifier will block **the** return of data, resulting in no search fixture;
- All fixture must be set to DMX mode to ensure only one host on the cable.
- A 120 ohm impedance matching resistor must be inserted between terminals 2 and 3 of the terminal plug. When the signal line is longer, reducing the signal reflection will make the differential signal more stable and beneficial to the quality of communication.
- When the fixture appears to accept DMX control, but can not be search by RDM host, first check the signal amplifier, and then check whether the signal line 2, 3 lines have bad contact.

Chapter 2 Panel operation

1. Brief

The diagram of the display panel show as **错误! 未找到引用源。**, above area is title for fixture description, the white font in the lower right corner shows the fault status of the fixture (when the fault information is not viewed, it displays "ERR", otherwise it displays "NOR"), and the status bar below shows the signal of the current fixture, fixture status, communication status, etc. (the panel in the figure is an example picture and does not represent the real appearance of the product panel, please select the panel of the same type as your product for reference.).

RDM protocol is embed in fixture, user set DMX address via cable using the controller support RDM function. when fixture was search by controller, displayer will echo 'RDM' indicate this RDM is work.

Note: Prevent damage the TFT displayer, Can not use sharp objects chick displayer.

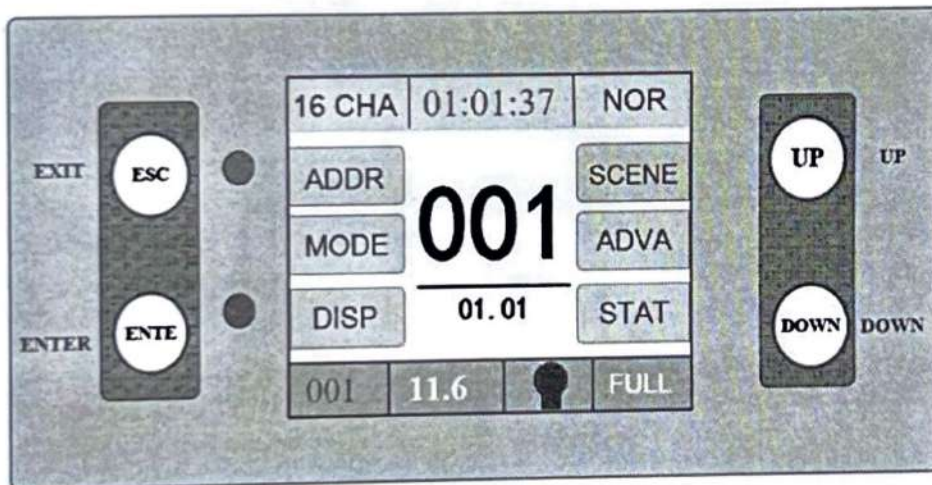

Figure 3 Diagram of the Spring button display panel

Operation

Operate fixture with touch button

- The middle area is the display area, both sides of the area is the input area, you can use the touch key to control the cursor to select the item that needs to be set or viewed, and press the "ENTE" button to complete the operation.

Parameter value setting

When the selected item is value need to been modified, the dialog shown in Figure 4 will popup.



Figure 4 Dialog of value setting

- **Modify value:** The desired value can be set by pressing the "Up" and "Down" buttons.
- **Save Value:** After setting the data by pressing the button, press the "ENTE" button, the values are immediately saved to the internal memory, and the saved values are applied to the fixture the next time the machine is turned on.

Boolean parameter setting

- when the selected parameters is a Boolean value (such as ON or OFF), can directly modify setting by click corresponding item, the setting will be saved right now.
- When the parameter is a key item, click corresponding item, a dialog shown in Figure 5 will be popup ask for the confirm. Click 'sure' to confirm.



Figure 5 Dialog of confirm

Sub Menu (Parameter)



Figure 6-1 Address setting

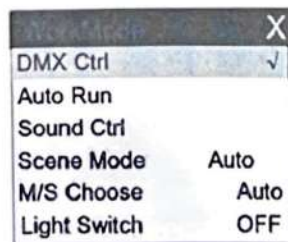

Figure 6-2 Run Settings

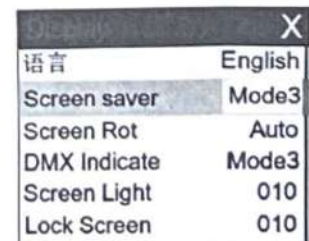

Figure 6-3 Display Settings

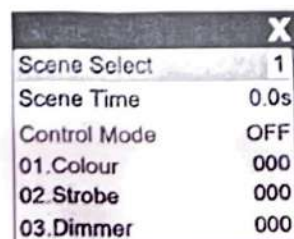

Figure 6-4 Scene Settings



Figure 6-5 Advanced setting

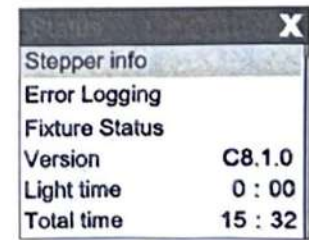

Figure 6-6 Status Settings

Figure 6 Diagram of the Parameter menu

Anti-false touch operation of key

If the product chooses the operation mode of the touch button, because the touch button is non-mechanical pressing (capacitive induction mode), in order to prevent accidental False touch, the operation menu mode or data of the fixture equipment will be accidentally changed. The product has added the anti-accidental button of the operation menu to unlock the confirmation page. You need to enter the menu to modify the mode or data of the fixture , and you can click the corresponding button in turn according to the prompts on the display.

- After a period of time, the display screen will enter the button anti touch locking interface, There are two types of screens (please select the interface that matches the product you hold),as shown in Figure 7 below.

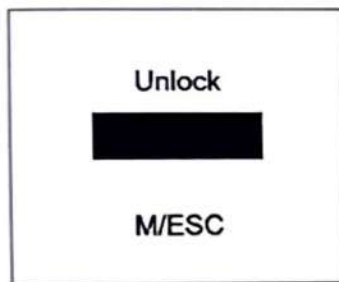

Figure 7-1

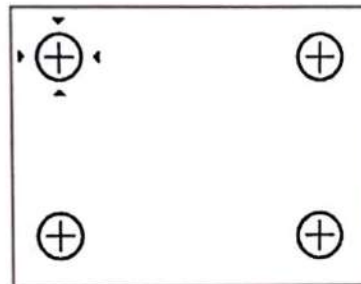

Figure7-2

- For the interface shown in Figure 7-1, press "ESC", "ENTER", "UP", and "DOWN" corresponding to the text that appears at the bottom of the screen to unlock it.
- For the interface shown in Figure 7-2, if you press a button when prompted, the red icon of the corresponding button will turn black. After that, the red logo will move to the next button position, after pressing the four corresponding buttons in order, you can exit the anti touch locking interface. If the corresponding position button icon is still red after pressing the key, it means that the wrong button was pressed.
- After power-on, when you edit the fixture parameters, it will trigger to enter the anti touch locking interface. If you just browse the parameters, it won't trigger entry; When the "lock screen" function is turned on, after not operating for a period of time, the anti touch locking interface will be entered when editing the fixture parameters; When the "lock screen" function is turned off, it only enters the anti touch locking interface when editing the fixture parameters after power-on. When you unlock the anti touch locking interface, you will not enter again during the current power-on cycle.
- In order to prevent the "lock screen" function from being turned off due to false touch. When the "lock screen" function is turned on, after pressing the "ENTER" button for the "lock screen" option, the anti touch locking interface will be entered, which will prompt that the "lock screen" function will be turned off; And when the "lock screen" function is turned off, you can turn on the function directly.

Operation and parameter instruction

Chick item of main menu, enter corresponding sub menu shown in Figure 6, In main menu, chick 1/6 function button into corresponding parameter menu.

1. DMX Address setting

Enter page show in Figure6-1, can set fixture DMX address, channel mode and so on.



Figure 7-1

The menu settings of fixture have optimized the setting of addresses. Several settings of the address are as follows:

- Select " Prev " or "Next", the fixture will be based on the current address and channel mode, automatically calculate the next or last address, make address setting can quickly;
- Click on the address value, you can enter the numeric editing window, where you can set any valid address, fixture system automatically get the current number of channels, automatically filter the unusable address (512 - the current number of channels).
- Fixture support RDM protocol, remote address can be set through RDM.

Provide one buttons:

- Channel mode:: you can choose different channel modes by cycle.

Fixture operating mode setting

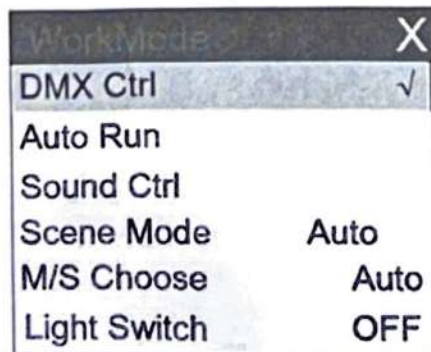

Figure 8-2

Through the page shown in Figure 6-2, the operating mode of the fixture can be set and the lamp can be controlled. The fixture supports four operating modes (DMX mode, auto mode, voice control mode and scene mode). Detailed parameter settings can be refer in the previous section. Specific parameter descriptions are as follows:

operating mode

DMX Ctrl	DMX mode, receive DMX signal, RDM signal
----------	--

Auto Run	Fixture run automatically according to built-in programs	
Sound Ctrl	When the fixture detects a strong sound, the fixture automatically runs a scene according to the built-in program, otherwise it will stay the last scene	
Scene Mode 01	runs in a set scene, which supports most of the custom editing of 10 scenes.	
	1~10	outputs the specified scene
	Auto	Automatically loops the output scene in the set scene time (non-zero) order, and the scene with time 0 automatically ignore
M/S Choose	Master and slave selection, non-DMX mode takes effect, select the mode of data output, fixture detect DMX cable state automatic switch output, prevent data conflicts	
	Master	fixture runs built-in program. If DMX has no signal, it outputs data (synchronization), otherwise it does not output data.
	Slave	fixture runs built-in program and do not output data
	Auto	If DMX has no signal, the fixture will runs built-in program. Otherwise, the fixture will run in DMX Mode(follow DMX).
Lamp switch	(Lamp light source) pop-up confirmation dialog box, select "SURE" to confirm the current operation, turn on or off the lamp, switch time interval limited to 30 seconds	
	Off	the current lamp output is off
	On	The current lamp output is turned on

Scene mode applies to a single or a small number of fixture, just output a fixed scene, or need to run a simple program, you no need connect to the console, in the scene page can be edited. If the light source is lamp, wait for 10 minutes before turning off the lamp.

Set display

语言	English
Screen saver	Mode3
Screen Rot	Auto
DMX Indicate	Mode3
Screen Light	010
Lock Screen	010

Figure 9-3

The fixture support Chinese and English, invert display and so on. Enter the corresponding parameter settings as shown in Figure 6-3. The specific menu contents are as follows:

DISPLAY SETTING

Language	display language settings	
	English	English display
	Chinese	Chinese display
Screen saver	Set screen 30 seconds without operation, the screen's display content or method	
	OFF	Keep the last operation page
	Model	Black

	Mode2	Black screen, showing the address code of the current fixture in the lower left corner.
	Mode3	Display trademark information, address code and operation mode.
	Mode4	Display trademark information, address code and operation mode, which lasts for 30 seconds, black screen.
Screen Rot		Set the display direction of the screen.
	OFF	No reverse display
	ON	Reverse display
DMX Indicate		Set the indication mode of DMX signal indicator.
	Mode1	When signal is bright, no signal is off.
	Mode2	When signal is off, no signal is bright.
	Mode3	When signal is flash, no signal is off.
Screen Light		Set the screen backlight for 10 seconds without operation
	1~10	10
Lock Screen		Set whether to open the anti touch locking interface.
	OFF	Only after power-on, editing the fixture parameters will enter the anti touch locking interface once.
	ON	After a period of no operation, editing the fixture parameters will enter the anti touch locking interface.

Scene

Enter the page shown in Figure 6-4 (The channel shown in the picture is only an example of the function, please refer to the channel table description in the next section for the specific channel table of this product), and the fixture enters the scene editing mode. For example, under this page, when the [Control Mode] option is turned off, the fixture does not receive DMX console data, and the edited data will effect on the fixture immediately. When it turned on, the console signal is received and the console data is read and reflected on the corresponding channel display.

X	
Scene Select	1
Scene Time	0.0s
Control Mode	OFF
01.Colour	000
02.Strobe	000
03.Dimmer	000

Figure 10-4

The content of the page depends on the currently selected channel mode, and the channel content and order displayed are consistent with the fixture channel table. Through this page, you can edit 10 scenes, as shown in the following table:

SCENE MODE

Scene Select	Select the current operation scenario.
--------------	--

	1-10	The 10 scenes sets the format
Scene Time	Sets the retention time of the current scene when it is automatic, the final time is determined by the scene time multiplier, unit in 0.1 seconds.	
	0	The current scene is not output in automatic scene output.
	1-255	0.1s-25.5s
Control Mode	Choose whether to use the console to manipulate the settings data	
	OFF	It is not possible to control the console and set the data directly from the current interface
	ON	Using console control, the console data comes first when setting, and the setting is invalid in the current interface
1. PAN	0-255	Set up the data of each channel, and the contents and order of the display are one-to-one correspondence with the channel list of fixture.
*****	0-255	
*****	0-255	
N. Function	0-255	

If the reset channel in the scene edits the effective reset data, the fixture will reset, but after reset, the corresponding reset channel value will automatically set 0, preventing multiple consecutive resets.

Looking at this page, you can get the current channel table slot of the fixture. For specific channel data, please refer to the detailed channel description.

Set light run parameter

Advanced		X
Pan Invert		OFF
Tilt Invert		OFF
P/T Rectify		ON
Pan Offset		010
Tilt Offset		010
Data hold		OFF

Figure 11-5

Enter the page shown in Figure 6-5, adjust the field parameters of fixture, facilitate the installation of fixture, etc.

ADVANCED SETTING

Pan Invert	Set the rotation direction of PAN	
	OFF	
	ON	
Tilt Invert	Set the rotation direction of TILT	
	OFF	
	ON	
P/T Rectify	Setting up fixture to detect XY lost step and correct	
	OFF	Uncorrected position after out of step

	ON	After losing step, the position is automatically corrected and the out of step fault is recorded.
Pan Offset	Setting the zero point of the PAN of the fixture	
	4-150	
Tilt Offset	Setting the zero point of the TILT of the fixture	
	4-48	
Data hold	When the fixture is not equipped with DMX signal, the output state of the fixture	
	OFF	No signal, so the motor and light source return to the position and state when reset is completed.
	NO	No signal, keep the last frame DMX data output.
Scene Time (multiple)	Work with the scene time to determine the scene retention time	
	1-255	Retention time = Scene time * multiple
Lamp mode	(lamp light source) Set the way to first open the lamp after power up	
	Power on	Turn on the lamp at power up and reset the lamp after 30 seconds.
	After reset	Reset the fixture after 3 seconds when power-on, and turn on the lamp after reset.
	Manual	After reset, manually turn on the lamp through the menu or console.
Reset	Pop up the confirmation box, select "SURE", and reset the fixture.	
Factory Setting	Pop up the confirmation box, select "SURE", and return the lamp parameters to the factory settings.	

When choosing power-on mode, the lamp will wait for 30 seconds after power-on, let the lamp fully start, internal voltage is stable enough, then start the reset program, if the field capacity is stable, recommend power-on mode.

When the fixture can not calibrate the position, please check whether the "P/T Rectify" is turned off.

When the signal is unplugged, check the Data Hold setting first if the position of the fixture is not output as expected.

When setting the XY offset, after setting up, please control XY with the maximum stroke first to check that XY will not bump into the positioning rod or shell.

Status and information

Status	
Stepper info	
Error Logging	
Fixture Status	
Version	C8.1.0
Light time	0 : 00
Total time	15 : 32

Figure 12-6

Entering the page shown in Figure 6-6, you can view the information and real-time status of the fixture to get their usage status. If the fixture need customer service, please provide the status

information displayed on the page as a basis for judgment, as shown in the following table:

STATUS INFORMATION

Stepper info	Display information status of all motors and signals in fixture.	
	Hall	No display, indicating that the motor has no Hall, 0 indicating that the motor leaves the correction position point, 1 indicating that the motor is in the correction position point
	Status	Display motor reset status
	PAN	Display real-time position value of PAN optocoupler feedback
	TILT	Display real-time position value of TILT optocoupler feedback
	PAN OP	Displays the PAN TILT optocoupler two signal level state, binary
Error Logging	Show the latest 8 error records when the fixture is reset and running. The error records are not saved after power failure. The current power cycle is valid.	
	Error Logging	Total number of failures detected after power on
	12: :03	The time of power failure when the fault occurs is in minutes.
	Hall error	The effective hall signal is not detected when the motor is reset
	Hall short	When the motor is reset, the hall signal of the motor is always effective
	Opti error	No effective optocoupler signal is detected when the motor is reset.
	Lose stop	The corresponding motor is out of step during its operation.
	Hit	Striking the positioning rod when the motor is reset
	Lamp error	Lamp explosion accident
	NTC error	The temperature sensor signal is abnormal
	Fan error	The main fan is not working properly.
Fixture status	Displays the critical state data of the current fixture for reference.	
	Communication prec	0~100%, Communication quality of internal data link of lamps and lanterns
	Error Cnt	The number of erroneous frames was detected after power on, and the total number of erroneous frames was detected.
	Light Temperature	Show the temperature of the current light source, "---" means no detection.
	Panel Temperature	Displays the temperature of the current display panel or the ambient temperature.
	Sensor1 Temperature	Display the ambient temperature of the motherboard temperature or the motherboard installation position.
Version	Display the information and version of the current fixture, important reference for after sales maintenance.	
	Device	The name of the fixture is the same as the equipment information of RDM.
	Model	The type of fixture is the same as the model information of RDM.
	Panel	Firmware version and serial number of display panel
	Main Board	Firmware version and serial number of mother board 1
Light time	Record the total cumulative time of light source opening, unit minute, user manual cleaning, as a reference for regular maintenance of light source time.	

Total time	The total accumulated time for recording the opening of fixture is not allowed to be removed.
------------	---

Chapter 3 Channel description

1. Channel table

This luminaire channel can be viewed in scene mode in order, channel mode is set in the "Address Settings" page, specific details of the data as follows: **错误! 链接无效。**

24CH	FUNCTION	VALUE	DESCRIPTION
CH1	Pan	0-255	0-540(degree)
CH2	Pan Fine	0-255	0-2(degree)
CH3	Tilt	0-255	0-270(degree)
CH4	Tilt Fine	0-255	0-1(degree)
CH5	PT Spd	0-255	Fast to slow
CH6	Dimmer	0-255	0-100% dimmer
CH7	Strobe	0-3	Dark
		4-103	Strobe slow to fast
		104-107	Open
		108-207	Fade Out strobe slow to fast
		208-212	Open
		213-251	Rand strobe slow to fast
		252-255	Open
CH8	Color	0-9	White
		10-19	Colour1
		20-29	Colour2
		30-39	Colour3
		40-49	Colour4
		50-59	Colour5
		60-69	Colour6
		70-79	White+colour1
		80-89	Colour1+Colour2
		90-99	Colour2+Colour3
		100-109	Colour3+Colour4
		110-119	Colour4+Colour5
		120-129	Colour5+Colour6
		130-190	Rotate forward (fast to slow)
		191-192	Stop
		193-255	Rotate reverse (slow to fast)
CH9	CTO	0-255	
CH10	Cyan	0-255	
CH11	Magenta	0-255	
CH12	Yellow	0-255	
CH13	Gobo	0-9	White
		10-19	Gobo1

		20-29	Gobo2
		30-39	Gobo3
		40-49	Gobo4
		50-59	Gobo5
		60-69	Gobo6
		70-79	Shake slow to fast Gobo1
		80-89	Shake slow to fast Gobo2
		90-99	Shake slow to fast Gobo3
		100-109	Shake slow to fast Gobo4
		110-119	Shake slow to fast Gobo5
		120-129	Shake slow to fast Gobo6
		130-200	Rotate reverse (fast to slow)
		201-204	Stop
		205-255	Rotate forward (slow to fast)
CH14	Eft Gobo	0-255	
CH15	Zoom	0-255	Large to small
CH16	Focus	0-255	Far to near
CH17	Rot Gobo	0-9	White
		10-19	Gobo1
		20-29	Gobo2
		30-39	Gobo3
		40-49	Gobo4
		50-59	Gobo5
		60-69	Gobo6
		70-79	Gobo7
		80-89	Shake slow to fast Gobo1
		90-99	Shake slow to fast Gobo2
		100-109	Shake slow to fast Gobo3
		110-119	Shake slow to fast Gobo4
		120-129	Shake slow to fast Gobo5
		130-139	Shake slow to fast Gobo6
		140-149	Shake slow to fast Gobo7
		150-202	Rotate forward (fast to slow)
		203-204	Stop
		205-255	Rotate reverse (slow to fast)
CH18	Gobo.Rot	0-127	0-360(degree)
		128-187	Rotate reverse (fast to slow)
		188-195	Stop
		196-255	Rotate forward (slow to fast)
CH19	Prism1	0-127	None
		128-255	Inert prism1
CH20	Prism1.R	0-127	0-360(degree)
		128-187	Rotate forward (fast to slow)

		188-195	Stop
		196-255	Rotate reverse (slow to fast)
CH21	Prism2	0-127	None
		128-255	Insert prism2
CH22	Prism2.R	0-127	0-360(degree)
		128-187	Rotate forward (fast to slow)
		188-195	Stop
		196-255	Rotate reverse (slow to fast)
CH23	Frost	0-127	None
		128-255	Insert frost
CH24	Reset	0-209	None
		210-215	Reset XY motor over 3 second
		216-219	None
		220-235	Reset Effect motor over 3 second
		236-239	None
		240-255	Reset fixture over 3 second

ONE
—PRO—