



UKAS ACCREDITED CALIBRATION CERTIFICATION

The part numbers shown below are for 'As Found', for new manual torque multiplying gearboxes up to the maximum capacity shown.

<b>12</b>	<b>ONE DIRECTION</b>
HTCC2.CW	Up to 6,000 N·m / 5,000 lbf·ft
<b>12</b>	<b>TWO DIRECTIONS</b>
HTCC2.CW+CCW	Up to 6,000 N·m / 5,000 lbf·ft



HANDTORQUE® STANDARD SERIES

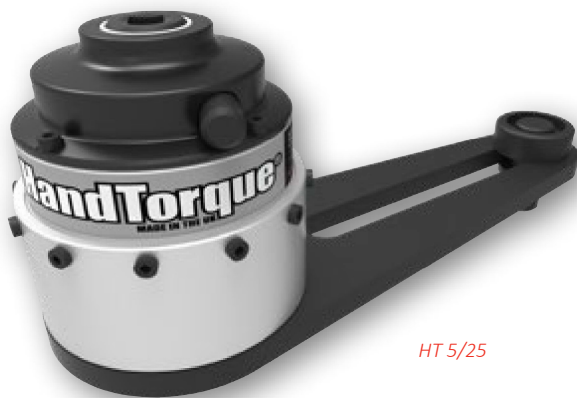

HT 5/25

- Mean torque multiplication accuracy ±4%
- High ratios allow the use of a small torque wrench, multipliers can be used where access is limited
- Anti Wind-Up Ratchet available on high ratio models
- Other reaction styles can be designed to suit specific applications
- Electronic torque transducers can be fitted for precise torque monitoring, see page 92
- Other models available up to 300,000 N·m
- If calibration is required, a UKAS accredited calibration certificate may be ordered (at extra cost) up to 6,000 N·m

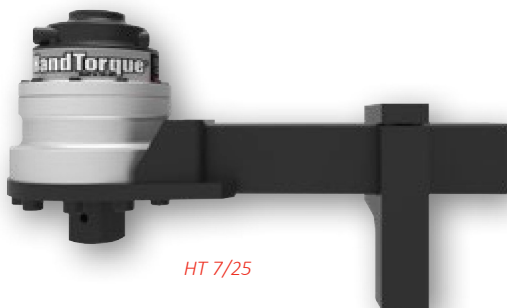

HT 7/25

4	STANDARD SERIES
16010	HT 1/5.2, 1,700 N·m, ½" in ¾" out
16012.HD	HT 2/5.2, 1,700 N·m, ¾" in 1" out
16034.HD	HT 2/27, 1,700 N·m, ½" in 1" out
16089.HD	HT 2/27 AWUR, 1,700 N·m, ½" in 1" out
16014	HT 5/5.2, 3,400 N·m, ¾" in 1" out
16028	HT 5/27, 3,400 N·m, ½" in 1" out
16090	HT 5/27 AWUR, 3,400 N·m, ½" in 1" out
16016	HT 6/5.2, 3,400 N·m, ¾" in 1½" out
16024	HT 6/27, 3,400 N·m, ½" in 1½" out
16092	HT 6/27 AWUR, 3,400 N·m, ½" in 1½" out
16093	HT 6/135 AWUR, 3,400 N·m, ½" in 1½" out
16067	HT 7/5.2, 6,000 N·m, ¾" in 1½" out
16018	HT 7/27, 6,000 N·m, ½" in 1½" out
16065	HT 7/27 AWUR, 6,000 N·m, ½" in 1½" out
16068	HT 7/135 AWUR, 6,000 N·m, ½" in 1½" out
16059	HT 9/27, 9,500 N·m, ¾" in 1½" out
16070	HT 9/27 AWUR, 9,500 N·m, ¾" in 1½" out
16071	HT 9/135 AWUR, 9,500 N·m, ½" in 1½" out
16082	HT 11/27, 20,000 N·m, ¾" in 2½" out
16049	HT 11/135 AWUR, 20,000 N·m, ½" in 2½" out
16053	HT 13/135 AWUR, 47,500 N·m, ½" in 2½" out

Other gear ratios may be available upon request.

If AWUR is not required please enquire for part number.

HT 13/135 fitted with weld prepared reaction ring as standard.

AWUR = Anti Wind-Up Ratchet. See page 44.

NOTE: Model name does not reflect multiplication ratios, see mean multiplication ratios on page 49

For spares kits for Norbar multipliers, please see page 130.



## HANDTORQUE® STANDARD SERIES



Model	HT 1/5.2	HT 2/5.2	HT 2/27	HT 2/27 AWUR	HT 5/5.2	HT 5/27	HT 5/27 AWUR	HT 6/5.2	HT 6/27	HT 6/27 AWUR	HT 6/135 AWUR
Part Number	16010	16012.HD	16034.HD	16089.HD	16014	16028	16090	16016	16024	16092	16093
Mean Multiplication Ratio	5.2:1	5.2:1	27:1	27:1	5.2:1	27:1	27:1	5.2:1	27:1	27:1	135:1
Dimensions (mm)	∅D	108	108	108	108	119	119	119	119	119	119
	H	83	98	98	114	106	127	132	106	128	134
	L	303	303	303	303	355	355	355	355	355	355
	R1	N/A	N/A	N/A	N/A	N/A	N/A	N/A	N/A	N/A	N/A
	R2 min.	83	83	83	83	86	86	86	86	86	86
	R2 max.	216	216	216	216	263	263	263	263	263	263
Tool Weight (kg)	3.0	3.2	4.6	6.7	4.7	6.4	7.5	4.7	6.4	7.5	9.0
Reaction Weight (kg)	2.2	2.2	2.2	2.2	2.5	2.5	2.5	2.5	2.5	2.5	2.5

Model	HT 7/5.2	HT 7/27	HT 7/27 AWUR	HT 7/135 AWUR	HT 9/27	HT 9/27 AWUR	HT 9/135 AWUR	HT 11/27	HT 11/135 AWUR	HT 13/135 AWUR
Part Number	16067	16018	16065	16068	16059	16070	16071	16082	16049	16053
Mean Multiplication Ratio	5.2:1	27:1	27:1	135:1	27:1	27:1	135:1	27:1	135:1	135:1
Dimensions (mm)	∅D	144	144	144	144	184	184	184	212	212
	H	136	157	162	188	166	162	182	208	235
	L	423	423	423	423	448	448	448	609	609
	R1	84	84	84	84	84	84	84	N/A	N/A
	R2 min.	150	150	150	150	175	175	175	320	320
	R2 max.	331	331	331	331	351	351	351	500	500
Tool Weight (kg)	8.1	9.6	10.7	12.2	16.3	17.4	18.9	31.7	32.1	95.2
Reaction Weight (kg)	6.3	6.3	6.3	6.3	8.3	8.3	8.3	13.3	13.3	6.9

