



HD 6/15 C



LISTA DE PEÇAS DE REPOSIÇÃO



LAVADORA A. P. HD 6/15 C – 1.150-617.0

OBS: TABELA DE ITENS TRANSFORMADOS EM KIT'S PÁG 20.



HD 6/15 C



CONTROLE DE REVISÃO							
Nº REVISÃO	REVISÃO	DO CÓDIGO	PARA O CÓDIGO	PÁG	POS	REVISADO	DATA
1	VÁLVULA CPL	4.580-311.0	4.580-254.0	5	4	Ricardo faria	02/10/2009
2	MOTOR COMPLETO	9.311-022.0	9.302-346.0	10	0	Marcelo cândido	19/04/2010
	DISCO OSCILANTE	6.401-289.0	6.401-256.0	10	12		
3	BUCHA DE FECHAMENTO	4.132-007.0	5.132-100.0	5	11	Marcelo cândido	24/06/2010
	ITEM INSERIDO O'RING	6.362-458.0	*	5	27		
4	GRAXA THERMOPLEX PARA REPOSIÇÃO	9.302-270.0 100g	*	9	*	Marcelo cândido	06/07/2010
		9.379-055.0 1Kg					
5	ABRAÇADEIRA DE NYLON	9.386-028.0	*	10	20	Marcelo cândido	20/07/2010
6	INCLUSÃO DA TABELA DE KIT'S	*	*	19	*	Marcelo cândido	27/07/2010
7	CABEÇOTE	5.550-302.0	9.369-259.0	5	9	Marcos Spagni	27/09/2010
8	UNIFICAÇÃO DE CODIGOS KNOB	5.326.026.0	53260350	2/3	10	RICARDO URBANO	23/02/2011
	UNIFICAÇÃO DE CÓDIGOS PORCA M6	7.311.061.0			12		
	UNIFICAÇÃO DE CÓDIGOS ARRUELA	7.312.260.0			19		
	UNIFICAÇÃO DE CÓDIGOSEIXO	5.100.443.0			25		
9	ITEM RETIRADO MANGUEIRA	6.388-216.0	9.311-512.0	3	18	Marcelo cândido	01/07/2011
	ITEM RETIRADO FILTRO	5.731-609.0		3	20		
10	TABELA DE REVISÃO MODIFICADA PARA PÁG 2	*	*	2	*	Marcelo cândido	10/01/2012
	FILTRO	6.414-252.0	9.391-003.0	5	2		
11	DESENHO DA BARRA DE ALUMÍNIO ATUALIZADO	*	*	3	27	Marcelo cândido	03/04/2012
	BARRA DE ALUMÍNIO	5.107-248.0	*	4	27		
12	ITEM REMOVIDO GRAXA THERMOPLEX COM EMBALAGEM DE 1Kg	9.379-055.0	*	10	*	Marcelo cândido	18/06/2012
	DESCRIÇÃO DA EMBALAGEM COM 100Kg ATUALIZADA PARA 50Kg	9.302-270.0	*	10	*		
13	ITEM INCLUIDO IMAGEM DA EXTENSAO	9.369-002.0	*	6	*	Marcelo cândido	26/06/2012
14	CAPÔ	5.069-048.0	9.340-046.0	4	1	Marcelo cândido	03/05/2013
15	IMAGEM DA HD 6/15 ATUALIZADA	*	*	1	*	Marcelo cândido	25/06/2013
	IMAGEM DA HD 6/15 INCLUIDA	*		3	*		
	CAPÔ	9.340-046.0	9.340-564.0	4	1		
	CALOTA	5.515-205.0	5.515-356.0	4	15		
16	IMAGEM DA HD 6/15 ATUALIZADA	*	*	1	*	Marcelo cândido	01/07/2013
	IMAGEM DA HD 6/15 ATUALIZADA	*	*	3	*		
	IMAGEM DO INTERRUPTOR INCLUIDA	*	*	16	2		
	INTERRUPTOR CPL	4.744-166.0	4.744-265.0	17	2		
17	CABO DE COMANDO COM TERMINAL	9.384-018.0	9.310-080.0	18	8	DANIEL ARAUJO	28/11/2013
18	MANGUEIRA PLAST ALTA PRESSAO 7,5M NEUTRA	9.389-051.0	6.389-565.0	13	17	DANIEL ARAUJO	10/01/2014
19	BICO TURBO SIMPLES 04	4.763-252.0	9.302-494.0	15	3	DANIEL ARAUJO	21/01/2014
20	Conector 3/4	6.465-031.0	*	5	28	Marry Silva	21/07/2015



HD 6/15 C



CONTROLE DE REVISÃO							
Nº REVISÃO	REVISÃO	DO CÓDIGO	PARA O CÓDIGO	PÁG	POS	REVISADO	DATA
20	Tampa	5.064-454.0	276.0	10	2	Marry Silva	05/11/2015
21	Conector 3/4	6.465-031.0	9.389-081.0	5	28	Marry Silva	06/11/2015
22	Tubeira	9.311-013.0	9.303-128.0	14	5	Marry Silva	07/12/2015



HD 6/15 C

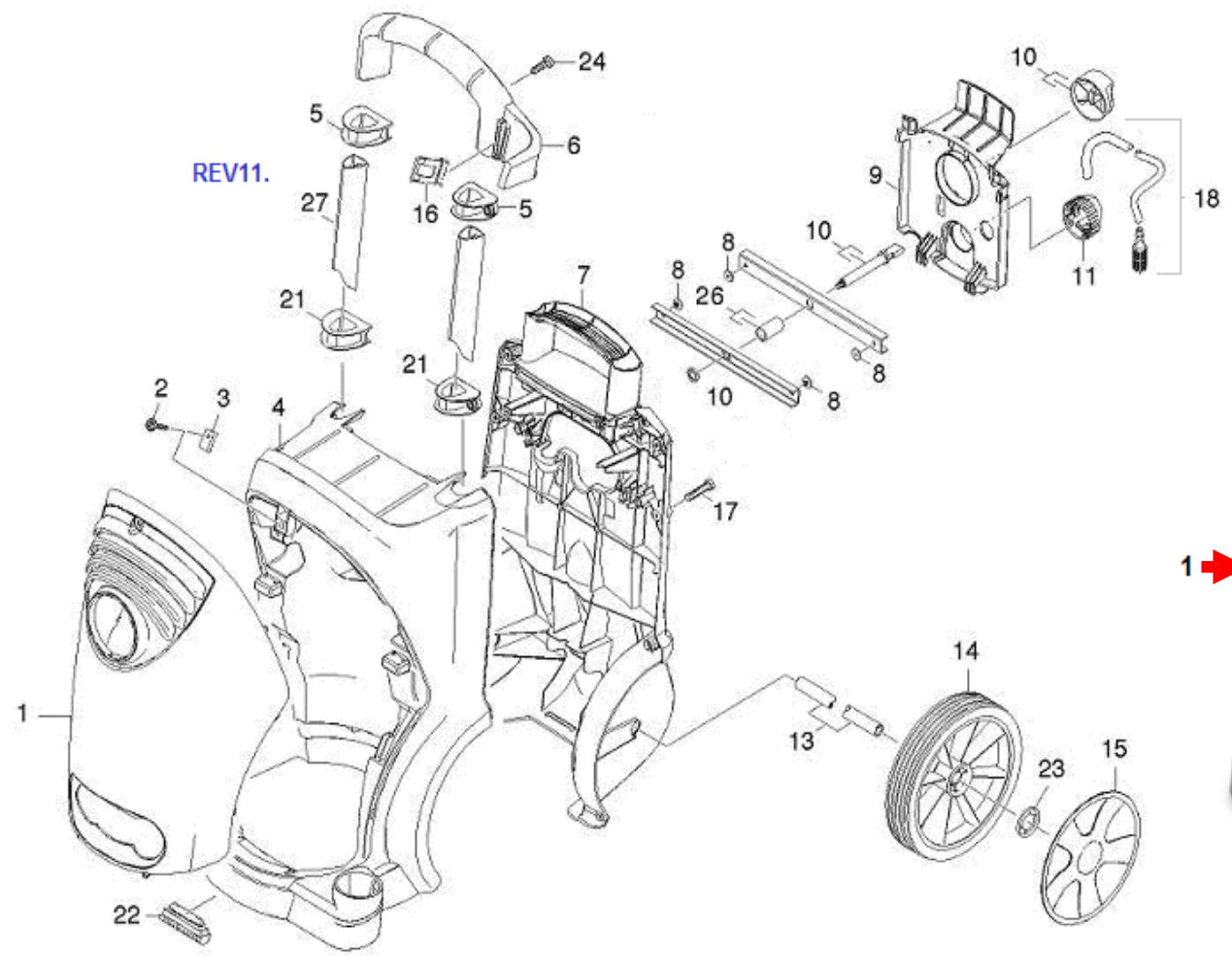



HD 6/15 C



POS.	DESCRIÇÃO	QTDE.	CÓDIGO	REV
1	CAPÔ CINZA	1	9.340-564.0	
2	PARAFUSO DE CABEÇA BOLEADA M6 x 18	1	6.304-099.0	
3	FIXADOR	1	6.310-053.0	
4	CHASSI HD 5/12 - 1º PEÇA	1	5.050-206.0	
5	GUIA	2	5.032-554.0	
6	ALÇA	1	5.321-721.0	
7	CHASSI HD 5/12 - 2º PEÇA	1	5.050-207.0	
8	REBITE	4	6.315-086.0	
9	COBERTURA	1	5.032-556.0	
10	BOTÃO GIRATÓRIO CPL	1	5.326-035.0	
11	VALVULA DOSADORA COMPLETA	1	4.063-778.0	
13	EIXO	1	5.105-399.0	
14	RODA Ø200	2	6.435-662.0	
15	CALOTA CINZA	1	5.515-356.0	
16	SUPORTE	2	5.044-216.0	
17	PARAFUSO AUTO AT. 5 x 20	10	9.386-170.0	
18	MANGUEIRA C/ FILTRO	1	9.311-512.0	
21	GUIA	2	5.032-555.0	
22	SUPORTE	2	5.057-062.0	
23	TRAVA DA RODA	2	6.343-168.0	
24	PARAFUSO M6 x 12	2	7.303-046.0	
26	BUCHA	1	5.116-091.0	
27	BARRA DE ALUMÍNIO	2	5.107-248.0	REV11



HD 6/15 C

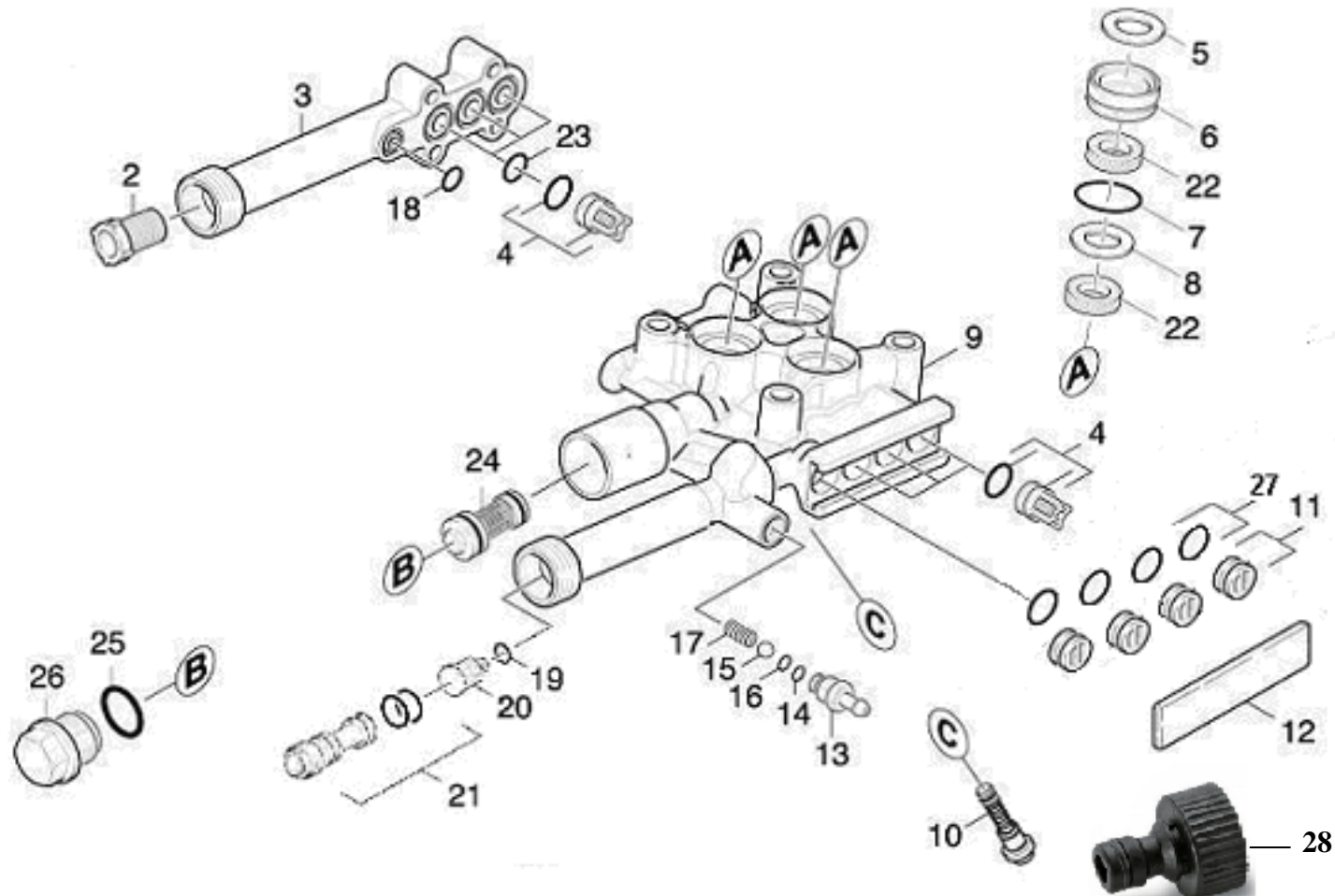



HD 6/15 C



POS.	DESCRIÇÃO	QTDE.	CÓDIGO
2	FILTRO	1	9.391-003.0
3	TAMPA DE ASPIRAÇÃO	1	5.064-150.0
4	VÁLVULA COMPLETA	6	4.580-254.0
5	ARRUELA	3	5.116-093.0
6	BUCHA	3	5.112-726.0
7	ORING 24 x 1,5	3	6.362-376.0
8	ARRUELA	3	5.115-721.0
9	CABEÇOTE	1	9.369.259.0
10	JOGO DE PEÇAS REPOSIÇÃO PISTÃO	1	2.884-501.0
11	BUCHA DE FECHAMENTO	4	5.132-100.0
12	PLACA	1	5.003-062.0
13	NIPLE	1	5.443-355.0
14	O'RING 6 x 2	1	6.362-113.0
15	ESFERA	1	7.401-908.0
16	O'RING 5,28 x 1,78	1	6.362-175.0
17	MOLA HELICOIDAL	1	5.332-258.0
18	O'RING 9 x 1,5	1	6.362-384.0
19	SELO DO ANEL 4 x 2	1	6.362-851.0
20	VÁLVULA DE RETENÇÃO	1	5.584-091.0
21	INJETOR COMPLETO	1	4.769-034.0
22	ANEL RANHURADO	6	6.365-477.0
23	O'RING 14 x 1,5	3	6.362-533.0
24	VÁLVULA BY PASS COMPLETA	1	4.591-038.0
25	O'RING 18 X 2,0	1	6.362-989.0
26	TAMPA ROSQUEADA	1	5.411-172.0
27	O'RING	4	6.362-458.0
28	Conector 3/4	1	9.389-081.0
100	CABEÇOTE CPL	1	4.550-675.0

* Para o CABEÇOTE código 9.369-259.0 não é necessário a EXTENSÃO código 9.369-002.0





HD 6/15 C



PISTÃO STOP TOTAL - POSIÇÃO 10		
DESCRIÇÃO	QTDE.	CÓDIGO
PARAFUSO DO PISTÃO DE CONTROLE	1	5.411-155.0
O'RING 9,5 x 2	1	6.362-528.0
MEMBRANA	1	5.367-030.0
PISTÃO DE CONTROLE	1	5.553-428.0
O'RING CPL 6,07 x 1,78	1	6.362-467.0
O'RING	2	6.363-074.0
ARRUELA	1	5.115-869.0
MOLA	1	5.332-157.0

VÁLVULA BY PASS - POSIÇÃO 24		
DESCRIÇÃO	QTDE.	CÓDIGO
TAMPA ROSQUEADA HD 5/12	1	5.411-172.0
O'RING 18 x 2	1	6.362-989.0
ASSENTO DA VÁLVULA	1	5.581-230.0
O'RING 12 x 2	1	6.362-169.0
PISTÃO	1	5.553-390.0
O'RING CPL - 2 PARBAKS	1	6.362-454.0
PARAFUSO DE FORMA	1	5.305-264.0
MOLA HELICOIDAL	1	5.332-258.0



HD 6/15 C

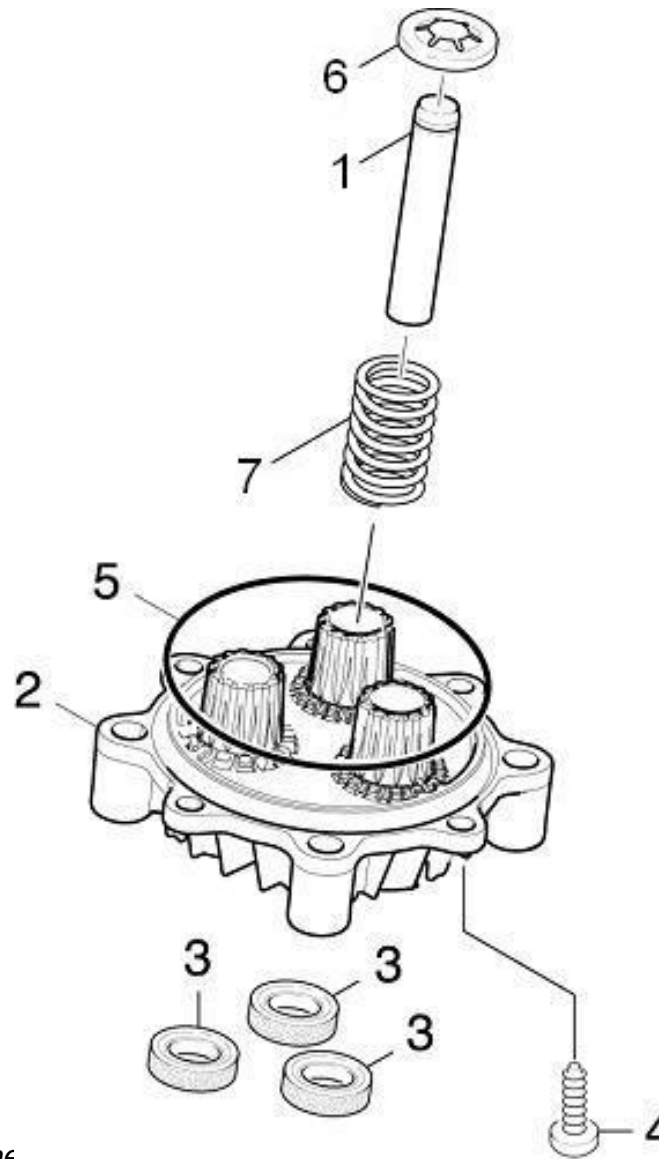



HD 6/15 C



POS.	DESCRIÇÃO	QTDE.	CÓDIGO
1	PISTÃO	3	5.553-469.0
2	GUIA DOS PISTÕES	1	5.061-018.0
3	ANEL RASPADOR	3	6.365-393.0
4	PARAFUSO M6 x 16	2	7.306-090.0
5	O'RING	1	6.363-252.0
6	ARRUELA TRAVA	3	5.116-092.0
7	MOLA	3	5.332-517.0



HD 6/15 C

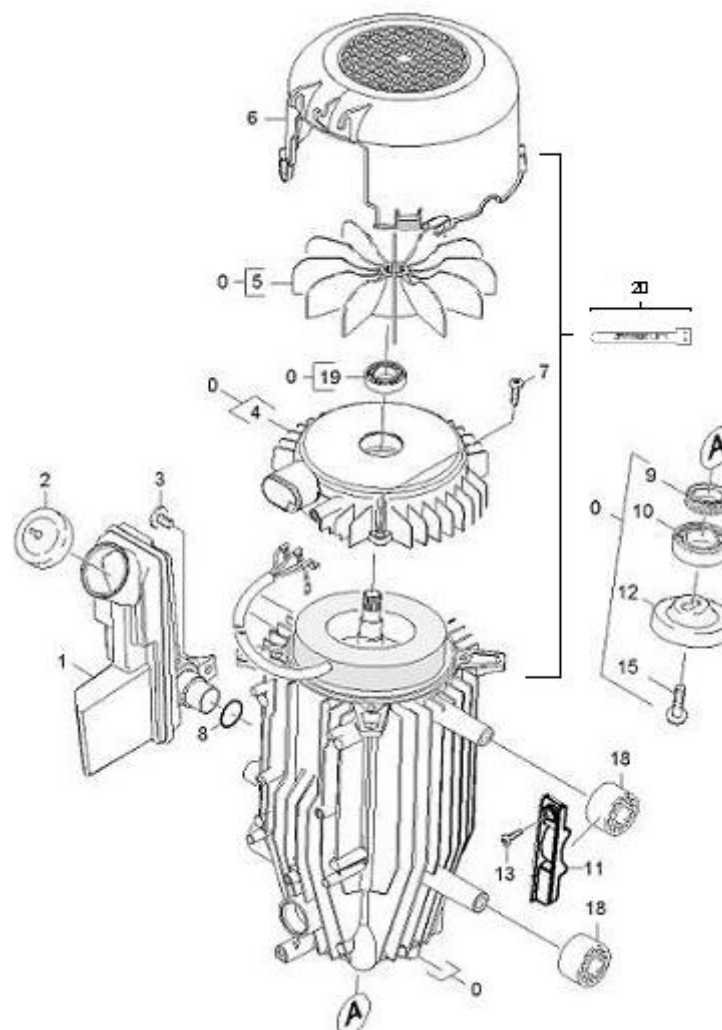

Especificação da graxa: Graxa Thermoplex.

Quantidade: 300 g.

Reposição: 9.302-270.0 embalagem com 50g .



HD 6/15 C



POS.	DESCRIÇÃO	QTDE.	CÓDIGO
0	MOTOR COMPLETO	1	9.302-346.0
1	TANQUE DE ÓLEO	1	5.070-639.0
2	TAMPA	1	9.340-276.0
3	PARAFUSO M5 x 15	1	6.303-153.0
4	TAMPA	1	5.094-127.0
5	HÉLICE	1	5.600-060.0
6	DIRECIONADOR DE AR	1	5.692-070.0
7	PARAFUSO M5 x 20	4	9.086-153.0
8	O'RING 19 x 2	1	6.362-161.0
9	RETENTOR	1	7.367-001.0
10	ROLAMENTO DE ESFERAS 6304	1	7.401-155.0
11	PEÇA DE MONTAGEM	2	5.802-288.0
12	DISCO OSCILANTE	1	6.401-256.0
13	PARAFUSO 5 x 20	2	9.386-170.0
15	PARAFUSO M8 x 16	1	9.086-169.0
18	AMORTECEDOR DE BORRACHA	4	5.767-005.0
19	ROLAMENTO DE ESFERAS 6202	1	7.401-128.0
20	ABRAÇADEIRA DE NYLON	2	9.386-028.0
20	OBS:ABRAÇADEIRA DE FIXAÇÃO ENTRE O DIRECIONADOR DE AR E MOTOR		



HD 6/15 C

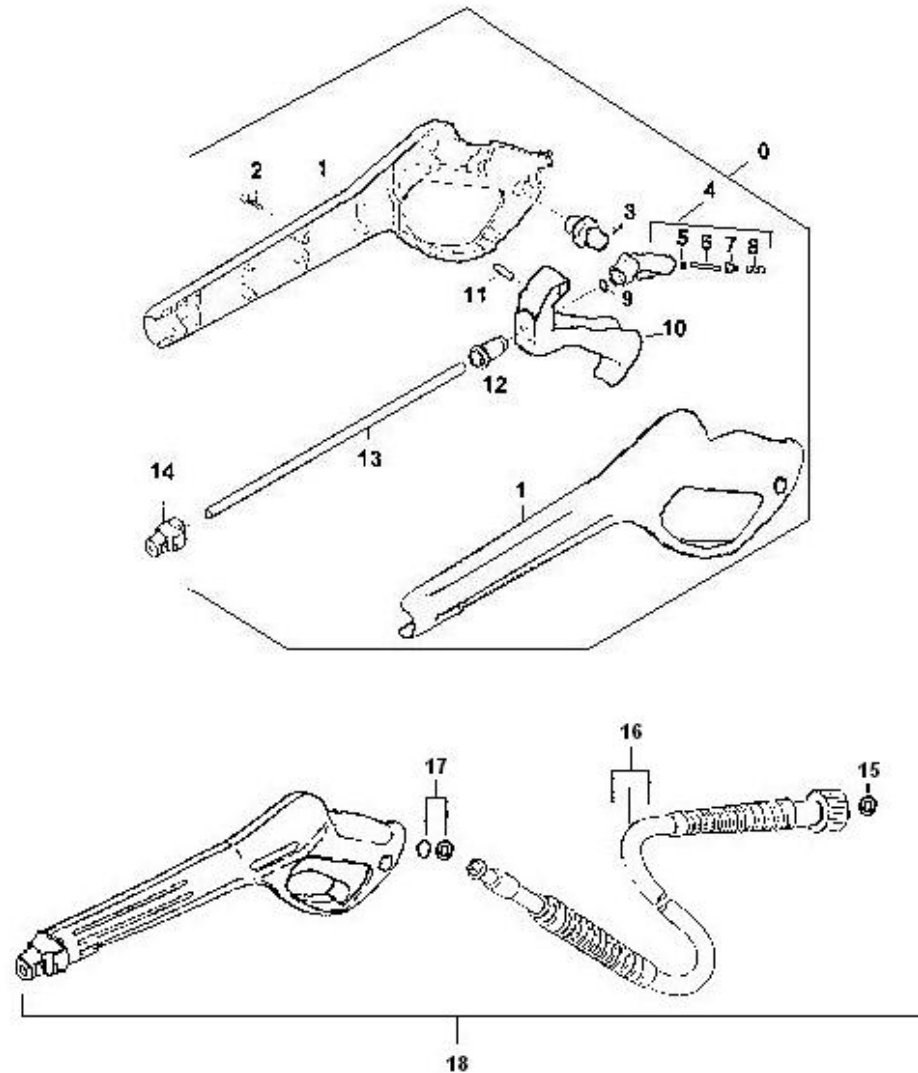



HD 6/15 C



POS.	DESCRIÇÃO	QTDE.	CÓDIGO
0	PISTOLA COMPLETA	1	9.311-032.0
1	CAPA DA PISTOLA	1	9.340-201.0
2	PARAFUSO 3,5 x 13	9	9.386-119.0
3	TRAVA DO GATILHO	1	5.481-189.0
4	CORPO DA PISTOLA	1	9.340-109.0
5	CORPO DA PISTOLA COMPLETO	1	9.311-312.0
6	O'RING 2,8 x 1,6	1	7.362-502.0
7	HASTE	1	9.369-158.0
8	ASSENTO DA VÁLVULA	1	5.582-058.0
9	MOLA	1	5.332-157.0
10	O'RING 7,59 x 2,62	1	6.362-479.0
11	GATILHO COM PINO	1	9.315-005.0
12	PINO DO GATILHO	1	5.314-082.0
13	BUCHA DA PISTOLA	1	5.110-539.0
14	TUBO INOX	1	5.028-905.0
15	TERMINAL COM ROSCA	1	4.402-049.0
16	O'RING 10X2	1	7.362-501.0
17	MANGUEIRA DE ALTA PRESSÃO	1	6.389-565.0
18	O'RING COMPLETO 6,07 x 1,78	1	6.362-422.0



HD 6/15 C

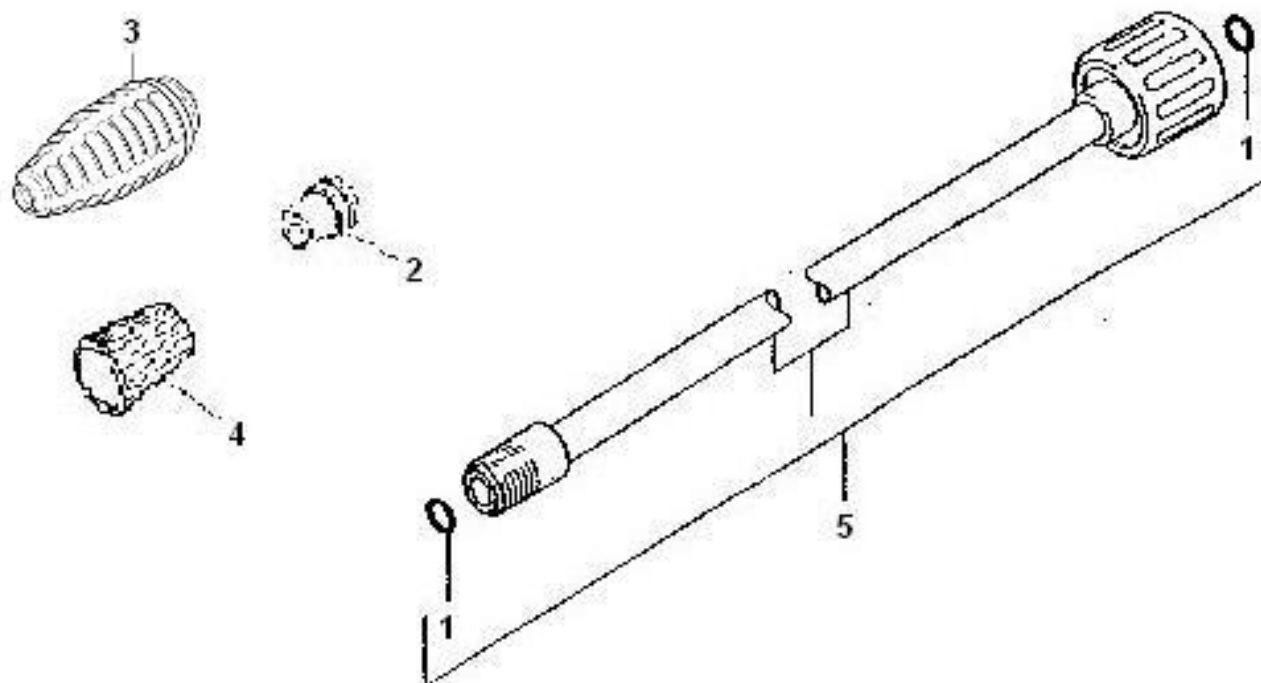



HD 6/15 C



POS.	DESCRIÇÃO	CÓDIGO	QTDE.
1	O'RING 10X2	7.362-501.0	1
2	BICO POWER 2504(ALTA PRESSÃO)	5.765-050.0	1
2	BICO RETO 0004 (ALTA PRESSÃO)	2.884-533.0	1
2	BIVO 25250(BAIXA PRESSÃO)	9.371-008.0	1
3	BICO TURBO 040(ALTA PRESSÃO)	9.302-494.0	1
4	PORCA CAPA	5.401-210.0	1
5	TUBEIRA 400MM	9.303-128.0	1



HD 6/15 C

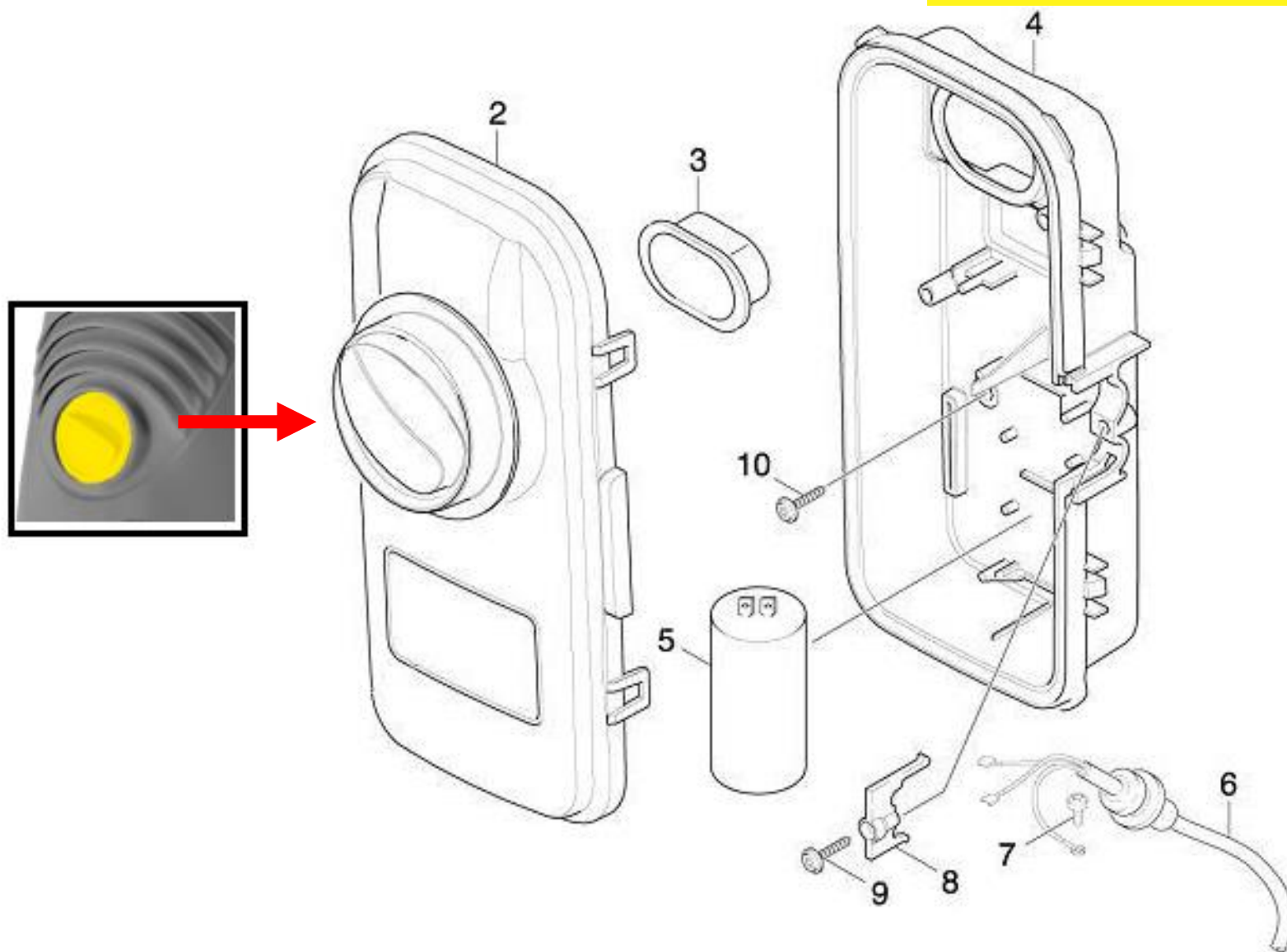



HD 6/15 C



POS.	DESCRIÇÃO	QTDE.	CÓDIGO
2	INTERRUPTOR CPL	1	4.744-266.0
3	JUNTA PERFILADA	1	5.365-181.0
4	CORPO CAIXA ELETRICA	1	5.061-000.0
5	CAPACITOR 25MF/450V	1	9.385-052.0
6	CABO ELETRICO COM PLUG	1	9.384-102.0
7	PCC TRILOBULAR M4 X 10 T20	1	9.086-152.0
8	Peça de fixação	1	5.263-051.0
9	PARAFUSO 5x25-IN6RD	1	6.303-200.0
10	PARAFUSO M5x15-ST-R2R (IN6RD)	1	6.303-153.0



HD 6/15 C

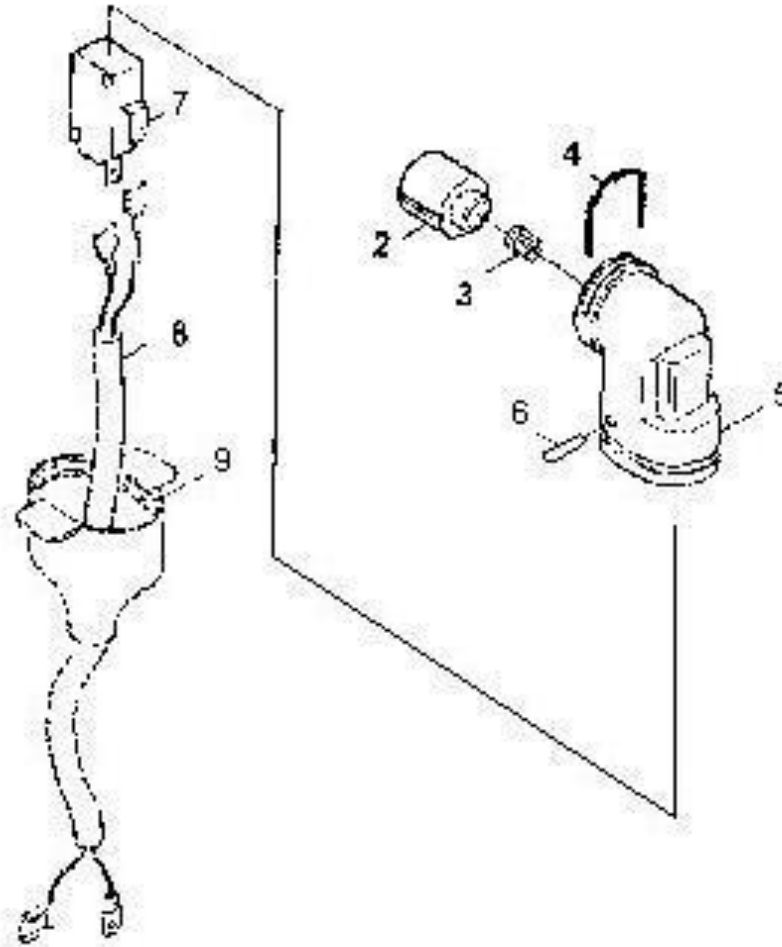



HD 6/15 C



POS.	DESCRIÇÃO	QTDE.	CÓDIGO
1	INTERRUPTOR COMPLETO	1	4.744-109.0
2	CONSOLE	1	5.053-051.0
3	MOLA	1	5.332-322.0
4	TRAVA STOP TOTAL	1	9.344-011.0
5	SUORTE DO MICRO	1	5.042-860.0
6	PINO ENTALHADO	1	7.314-664.0
7	MICROINTERRUPTOR	1	6.631-807.0
8	CHICOTE ELÉTRICO	1	9.310-080.0
9	PROTETOR DO MICRO	1	5.394-388.0



HD 6/15 C



TABELA DE ITENS TRANSFORMADOS EM KIT'S.

CÓDIGO	DESCRIÇÃO	CÓDIGO UNIT. P/ PEÇA	CÓDIGO	DESCRIÇÃO	CÓDIGO UNIT. P/ PEÇA
9.302-093.0	KIT VALVULA - KIT 10 PÇS	4.580-254.0	9.302-119.0	ANEL RASPADOR 12 X 20 X 4/6 KIT 10 PÇS	6.365-393.0
9.302-099.0	CONJ TAMPA CENTRAL VALVULA - KIT 5 PÇS	4.132-008.0	9.302-120.0	RETENTOR 26 X 35 X 5 - KIT 10 PÇS	6.367-095.0
9.302-100.0	CONJ TAMPA LATERAL VALVULA - KIT 10 PÇS	4.132-0090	9.302-121.0	INTERRUPTOR - KIT 5 PÇS	6.631-805.0
9.302-101.0	BUCHA LIGACAO CAB+GUIA - KIT 10 PÇS	4.363-016.0	9.302-122.0	INTERRUPTOR - KIT 5 PÇS	9.385-057.0
9.302-102.0	VALVULA DE SUCCAO K3XX - KIT 10 PÇS	4.580-281.0	9.302-123.0	O'RING 10 X 2 EPDM 70 - KIT 20 PÇS	7.362-501.0
9.302-103.0	VALVULA BY PASS - 120BAR - KIT 5 PÇS	4.580-284.0	9.302-124.0	GUIA DA GAXETA - KIT 10 PÇS	9.340-140.0
9.302-104.0	VALVULA ALTA PRESSAO K3XX - KIT 10 PÇS	4.580-285.0	9.302-125.0	JUNTA T BLOCO K3 - KIT 5 PÇS	9.364-002.0
9.302-106.0	MOLA - KIT 10 PÇS	5.332-001.0	9.302-126.0	JUNTA TAMPA VIRABR. - KIT 5 PÇS	9.364-003.0
9.302-107.0	MOLA DO PISTAO - KIT 6 PÇS	5.332-251.0	9.302-127.0	JUNTA T BLOCO K 2 - KIT 5 PÇS	9.364-004.0
9.302-108.0	MOLA DE RETORNO DO PISTAO - KIT 6 PÇS	5.332-345.0	9.302-128.0	ANEL VALVULA - KIT 10 PÇS	5.581-091.0
9.302-109.0	O'RING 6 X 2 NBR 70 - KIT 10 PÇS	6.362-113.0	9.302-129.0	DISCO DE VALVULA - KIT 10 PÇS	9.369-092.0
9.302-110.0	O'RING 12 X 2 NBR 70 - KIT 10 PÇS	6.362-169.0	9.302-130.0	JOGO DE GAXETAS 0 22 - KIT 6 PÇS	9.376-015.0
9.302-111.0	O'RING 6,07 X 1,78 NBR 70 - KIT 10 PÇS	6.362-176.0	9.302-131.0	RETENTOR 28X40X7 - KIT 6 PÇS	9.376-018.0
9.302-112.0	O'RING CPL 5,13 X 1,24 NBR 90- KIT 10 PÇS	6.362-368.0	9.302-132.0	ENGATE RAPIDO 3/4 AMARELO KIT 5 PÇS	9.389-078.0+ 93890810
9.302-113.0	O'RING CPL - KIT 10 PÇS	6.362-422.0	9.302-133.0	FILTRO (90 MICRA) - KIT 10 PÇS	9.391-003.0
9.302-114.0	GAXETA 12 X 20 X 5 K3XX - KIT 10 PÇS	6.362-875.0	9.302-134.0	PISTAO COMPLETO - KIT 3 PÇS	9.302-008.0
9.302-115.0	ANEL RASP 18 X 26 X 6/8 - KIT 6 PÇS	6.365-334.0	9.302-135.0	VALVULA DE RETENCAO CPL KIT 10 PÇS	9.302-013.0
9.302-116.0	GAXETA 18 X 26 X 5,4 - KIT 6 PÇS	6.365-333.0	9.302-136.0	PISTAO COMPLETO - KIT 3 PÇS	9.302-084.0
9.302-117.0	ANEL RASPADOR 14 X 22 X 7 - KIT 10 PÇS	6.365-340.0			
9.302-118.0	GAXETA 14 X 22 X 5,3/2,8 - KIT 10 PÇS	6.365-341.0			